

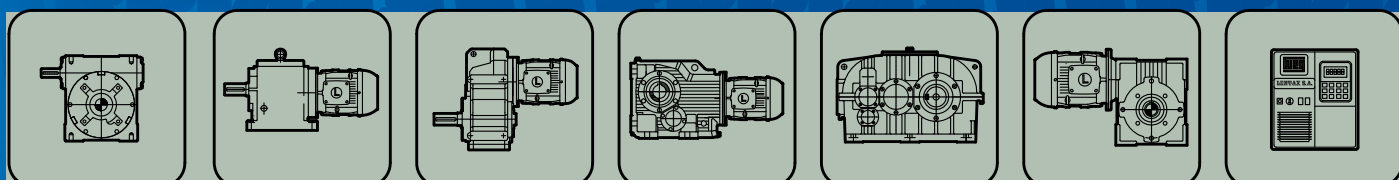

LINEA DE ENGRANAJES CÓNICOS

CATÁLOGO Nº 723

✓ Edición :
27-05-2025

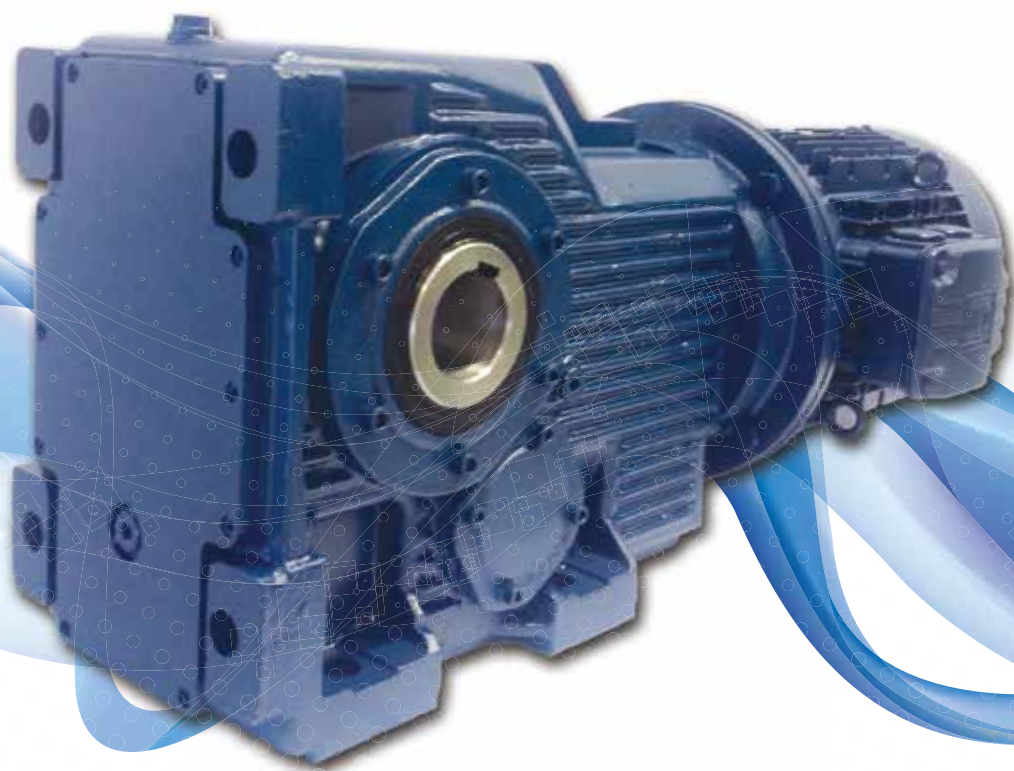

Programa de Fabricación - *Manufacture Summary*

Catalogo Nº/*Catalogue Nº*

MOTOREDUCTORES A SINFIN Y CORONA "LINEA UNIVERSAL"
REDUCTORES A SINFIN Y CORONA "LINEA UNIVERSAL"
WORM GEARED MOTORS "UNIVERSAL LINE"
WORM GEAR SPEED REDUCERS "UNIVERSAL LINE" **122**

MOTOREDUCTORES A ENGRANAJES COAXIALES
REDUCTORES A ENGRANAJES COAXIALES
IN LINE HELICAL GEARBOXES **222**

CONVERTIDORES DE FRECUENCIA, ARRANCADORES SUAVES, FRENOS
ANTIGIROS, VARIADORES Y MOTOVARIADORES DE VELOCIDAD
FREQUENCY INVERTERS, SOFT-STARTERS, BRAKEMOTORS, BACKSTOPS
MECHANICALLY ADJUSTABLE SPEED VARIATORS AND MOTO-VARIATORS **320**

MOTOREDUCTORES A SINFIN Y CORONA "LINEA BLOC 2"
REDUCTORES A SINFIN Y CORONA "LINEA BLOC 2"
WORM GEARED MOTORS "BLOC 2 LINE"
WORM GEAR SPEED REDUCERS "BLOC 2 LINE" **422**

REDUCTORES A ENGRANAJES
TRENES PARALELOS - ENTRADA CÓNICA
PARALLEL SHAFT SPEED REDUCERS
BEVEL - HELICAL GEAR UNITS **523**

MOTOREDUCTORES COMPACTOS A ENGRANAJES
MONTAJE CON EJE HUECO
FLAT HELICAL GEARBOXES
SHAFT MOUNTED **622**

MOTOREDUCTORES A ENGRANAJES
EJES ORTOGONALES - INTERMEDIA CÓNICA
ORTHOGONAL SHAFTS GEARBOXES
BEVEL - HELICAL GEARBOXES **723**

SERIES DE FABRICACION / STANDARD GEARDRIVES
FORMAS CONSTRUCTIVAS / BUILDING FORM

REDUCTOR PRINCIPAL / MAIN REDUCER

ACCIONAMIENTO / DRIVE

EJE HUECO
HOLLOW SHAFT

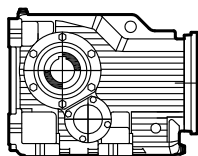

CON PATAS
FOOT MOUNTED

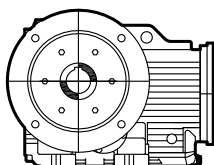

CON BRIDA
FLANGE MOUNTED

EJE MACIZO
SOLID SHAFT

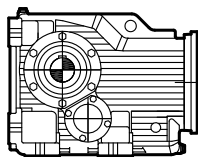

CON PATAS
FOOT MOUNTED

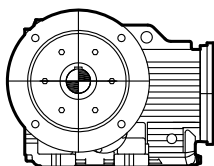

CON BRIDA
FLANGE MOUNTED

ANTECAJA / PRIMARY GEARBOX

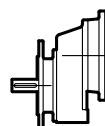

SIMPLE REDUCCIÓN
SINGLE REDUCTION

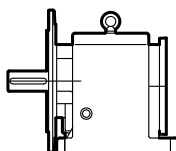

DOBLE O TRIPLE
REDUCCIÓN
DOUBLE OR TRIPLE
REDUCTION

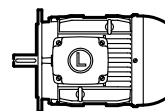

MOTOR NORMALIZADO
TRIFÁSICO / MONOFÁSICO
STANDARD IEC MOTOR

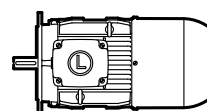

MOTOR CON FRENO
O DISPOSITIVO ANTI-RETROCESO
BRAKEMOTOR OR BUILT-IN BACKSTOP

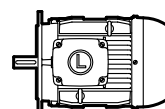

MOTOR ANTIEXPLOSIVO
EX MOTORS

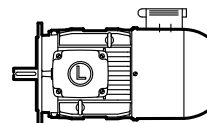

MOTOR DE CORRIENTE CONTINUA
DC MOTORS

REDUCTOR / REDUCER

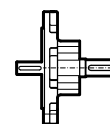

EJE DE ENTRADA
REDUCTOR
INPUT SHAFT

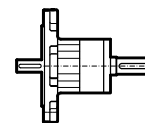

EJE DE ENTRADA
CON DISPOSITIVO ANTI-RETROCESO
INPUT SHAFT
WITH BACKSTOP

Empresa líder en la fabricación de motoredutores y reductores de velocidad con más de 50 años de actividad en el país, basada como siempre en su firme convicción de producir la más alta calidad del mercado y habiendo comprobado que en el país hacía falta una renovación tecnológica en este ramo, presenta su línea de reductores y motoredutores a engranajes con Calidad Internacional.

CARACTERÍSTICAS Y VENTAJAS DE ESTA SERIE

- Diseño modular con reducida cantidad de componentes y amplia gama de relaciones disponibles.
- Todos los engranajes y piñones cementados y templados y con flancos rectificadas ó afeitados según corresponda.
- Estricto control de calidad con equipos de medición de alta precisión para el dentado de engranajes únicos en el ramo.
- Alto rendimiento y funcionamiento suave y silencioso.
- Elevada duración.
- Producción económica debido a la posibilidad de fabricar componentes en serie y para stock.
- Diseño compacto con reducido peso y volúmen. Facilita el proyecto del usuario al requerir menos espacio y costos estructurales.
- Laboratorio metalográfico propio, para control de los materiales y su tratamiento térmico.

CONSTRUCCIÓN MODULAR

Nuestra nueva línea de cajas de engranajes ha sido diseñada de acuerdo a series standard de números normalizados. Esto significa, que los tamaños de los engranajes, las relaciones de transmisión y las principales dimensiones siguen una determinada progresión que permite racionalizar la producción, minimizar stock, reducir costos y contar con plazos de entrega breves.

El diseño de esta nueva línea es la culminación de muchos años de experiencia en la fabricación de diferentes series de elementos de transmisión.

ENGRANAJES

Todos los piñones y engranajes de esta serie de reductores de simple doble o triple reducción son construídos con aceros especiales de cementación y temple, obteniéndose de esta forma un dentado con elevada dureza superficial y gran resistencia al desgaste en combinación con un núcleo dúctil de excelente tenacidad. Posteriormente se rectifican los flancos de los

Lentax is a market leader in the design and manufacture of speed reducers and gearmotors with more than 50 years of experience servicing the toughest applications.

Our quality and dedication to our customers comes from the basic principle of creating the highest quality product using the latest technological advances in design and manufacturing.

This catalogue features our newly expanded line of helical gears speed reducers and accessories.

FEATURES AND BENEFITS.

- *Modular design using less components for greater reliability.*
- *All gears and pinions are machined from the highest quality materials and then heat treated and super finished to exacting tolerances for outstanding performance.*
- *Lentax maintains strict quality control of all gear tooth profiles using specialized equipment to ensure maximum meshing of each gear set.*
- *Lentax maintains a full metallurgic lab in house that constantly monitors metal quality and hardness.*
- *High performance, smooth and silent operation with exceptional durability.*
- *Large production runs ensure customers of quick deliveries and reduced production costs that make our speed reducers competitive on the world markets.*
- *Superior design techniques result in providing a more compact speed reducer design without sacrificing performance, allowing designers and users to scale down space and structural needs.*
- *Every speed reducer undergoes a strict multi point run-in test in our factory to ensure that you, the customer, can depend on a sure start each and every time.*

HELICAL GEAR SPEED REDUCER MODULAR CONSTRUCTION

This newly updated product line was carefully rationalized in order to provide the customer with an outstanding range of standard models to choose from. Lentax also integrated a new format of production scheduling that rationalizes production to ensure quick reaction times to all of our customer needs.

GEARS

All of the gear components used in our in-line speed reducers are manufactured from the highest quality case hardened alloy steel. The gear teeth are subsequently treated to obtain a perfect helicoidal profile that ensures the correct helical angle and

dientes lográndose así un dentado helicoidal con perfil corregido de elevada capacidad portante. Paralelamente, se realiza un estricto control de la evolvente de los dientes, el paso, el ángulo de hélice y la concentricidad de cada par de engranajes.

La concepción de modularidad aplicada al diseño de estas cajas, permite utilizar los pares de engranajes en diferentes tamaños de serie.

Estos engranajes se caracterizan también por su elevado rendimiento, (98.5 % por cada etapa) funcionamiento suave y gran durabilidad.

CAJAS REDUCTORAS

Todos los cuerpos reductores de esta serie son fabricados en fundición de hierro gris ampliamente dimensionados y provistos de nervios de refuerzo que aumentan su rigidez e indeformabilidad.

Las carcasas son monocasco (línea KL), confiriéndole mayor rigidez y elevada precisión en el mecanizado en centros de mecanizado C.N.C. de última generación.

RODAMIENTOS

Los reductores de esta línea están totalmente montados sobre rodamientos de rodillos ó bolas, según corresponda, de alta capacidad de carga.

EJES

Los ejes de entrada y salida están construidos con acero SAE 1045. Todos los asientos y puntas de ejes son rectificadas.

Ambos ejes van provistos de retenes de goma sintética que aseguran la estanqueidad del reductor y la consiguiente protección contra la entrada de polvo y salpicaduras de agua del exterior.

ACCESORIOS

Bajo pedido, los reductores pueden ser entregados con un mecanismo anti-retroceso que permite el giro del reductor en un solo sentido impidiendo su retroceso por efecto de las cargas externas.

Cuando sea necesario pueden ser provistos con trompa para agitador.

LUBRICACIÓN

El sistema de lubricación de estos reductores es por baño de aceite. La lubricación de los rodamientos es por salpicado o blindados según corresponda y queda asegurada debido al diseño especial del interior, que además permite la retención de parte del aceite en el rodamiento cuando el equipo está en reposo.

Las unidades son entregadas con su carga inicial de aceite de base mineral aditivado.

Para mayor información consulte nuestro Manual de Servicio.

concentricity of all the gear sets. This perfect matching of profiles allows for factory interchangeability of gear sets that reduces lead times while always providing speed reducers unrivaled for performance, durability and smooth quiet operation.

Lentax helical gear speed reducers exceed 98.5% efficiency per stage.

CASING

All of the casings in this series of speed reducers are designed and manufactured from close grained cast iron that includes integral ribs and reinforced sections to assure high physical strength and torsional stability to provide a long service life.

All of our speed reducers have matched covers and bases and are factory leak tested.

BEARINGS

Lentax uses only the highest quality ball and roller bearings in the production of these speed reducers.

All bearings are chosen with very generous safety margins to allow for high load capacities.

SHAFTS

All our shafts are made from high strength alloy steel, verified for trueness and diameter to exacting standards.

Highest quality oil seals render these units impervious to contamination from dust or water spray.

ACCESSORIES

These speed reducers can be ordered with an anti-reversing mechanism (backstop) that will prevent the speed reducer from turning backwards once the driving motor has stopped.

In addition, if the application requires it, these speed reducers can be ordered with a turret for agitator.

LUBRICATION

Lentax helical gear speed reducers use a highly efficient oil bath lubrication system that reaches all of the critical areas within the gear casing and due to the special design of the parts, the bearings retain some of the oil even when the unit has not been running, to prevent the possibility of dry starts after a shutdown. Lentax provide these gear boxes with a full crankcase of mineral oil.

For further information refer to our Service Manual.

SELECCIÓN DEL REDUCTOR

Debido a la diversidad de aplicaciones y condiciones de trabajo, a las cuales puede ser sometido un reductor perteneciente a una línea standard, los fabricantes dan las potencias transmisibles para determinadas condiciones de servicio (Carga uniforme, 8/10 hs. de servicio y accionamiento con motor eléctrico). Recomendamos seguir cuidadosamente los pasos que se detallan, para así poder lograr una correcta performance del equipo seleccionado y ante cualquier duda consultar a la fábrica.

PASOS A SEGUIR

- 1) Calcular la potencia absorbida (N_{abs}).
- 2) Calcular la potencia de entrada (N_e).
- 3) Determinar el factor de Servicio (f_s).
- 4) Calcular la potencia de entrada equivalente
 $N_{eq} = N_e \cdot f_s$
- 5) Calcular la relación ($i = n_e/n_s$).
- 6) Preseleccionar un modelo.
- 7) Comprobar que $N_{nominal} > N_{eq}$.**
- 8) Controlar la potencia de arranque
($N_{arr} < 2,5 \cdot N_{nominal}$)
- 9) Controlar las cargas radiales.

POTENCIA ABSORBIDA

Es la potencia teórica necesaria para el accionamiento. Dicho valor calculado y suministrado por el cliente, no debe incluir adicionales por condiciones de servicio.

POTENCIA DE ENTRADA

Esta potencia debe ser referida al eje de entrada afectando la Potencia Absorbida por el rendimiento del reductor. (98.5% por cada etapa).

FACTOR DE SERVICIO

En las tablas adjuntas, (ver pgs. 11 a 14) se detallan los factores de servicio correspondientes a la máquina accionada, tipo de motor de accionamiento y cantidad de arranques por hora.

POTENCIA DE ARRANQUE

Los reductores de esta serie, están calculados para resistir potencias de arranque y sobrecargas instantáneas de hasta 2,5 veces la potencia nominal. Cuando este valor sea superado, será necesario consultar a nuestro departamento técnico.

SELECCIÓN DEL MOTOREDUCTOR

La potencia del motor (N_m) multiplicada por el factor de seguridad del equipo (f_z) debe ser igual o mayor que la potencia equivalente. ($N_{abs} \cdot f_s / \text{rend}$).

SPEED REDUCER SELECTION

Due to the diversity of applications and working conditions that a speed reducer can be subjected to, manufacturers of speed reducers generally state the transmissible capacity for specific conditions of service. As an example, 8-10 hours a day, uniform load, and coupled to an electric motor.

When choosing your speed reducer requirements, take into consideration the actual service conditions and compare them to the figures shown on the tables.

HOW TO SELECT

- 1) Calculate the necessary Power (N_{abs}).
- 2) Calculate the Input Power (N_e).
- 3) Calculate the service factor (f_s).
- 4) Calculate the equivalent Input Power.
($N_{eq} = f_s \cdot N_e$).
- 5) Calculate the ratio. ($i = n_e/n_s$).
- 6) Preselect a model.
- 7) Verify that ($N_{nominal} > N_{eq}$).**
- 8) Determine the required starting capacity. ($N_{str} < 2.5 \cdot N_{nom}$).
- 9) Determine the radial load

NECESSARY POWER

This is the theoretical power required for proper operation not taking into account any additional service conditions, this should be calculated in relation to the input shaft.

INPUT POWER

This is the necessary power increased by the reducer efficiency.
 $N_e = N_{abs} / \text{efficiency}$

SERVICE FACTOR

Refer to the following tables and select the type of example that is comparable to your specific application. (If unsure, contact your closest Lentax representative for assistance).

STARTING CAPACITY

Lentax helical gear speed reducers have been designed to withstand up to 2.5 times normal load capacities on startup. Should your start up loads be greater, please check with the factory.

GEARMOTOR SELECTION

Must verify that: $N_{motor} \cdot f_z > N_{eq}$
 N_{motor} = Motor power
 f_z = Safety factor of gearmotor.

ENTREGA MANIPULEO MONTAJE

Todos los reductores se someten en fábrica a un período de marcha en vacío en el cual se verifica su correcto funcionamiento, estanqueidad y los datos de fabricación solicitados por el cliente.

Normalmente las unidades se entregan sin embalaje salvo que se lo solicite expresamente. El costo del mismo no está incluido en el precio de venta.

El equipo se debe levantar mediante lingas que lo rodeen totalmente, pasando por su base o mediante el cáncamo dispuesto para tal fin.

Para colocar acoplamientos, piñones de cadena o engranajes se debe utilizar el centro roscado de los ejes evitando hacerlo mediante golpes, aún cuando se haga sobre un taco de madera interpuesto.

Los ejes se entregan rectificadas con tolerancia ISO k6, recomendándose para las piezas a acoplar ISO H7, estas deberán ser fijadas axialmente mediante prisioneros. Los chaveteros se fabrican según DIN 6885 hoja 1.

El reductor deberá montarse sobre bases planas, niveladas y rígidas, esto es importante para asegurar la correcta lubricación y evitar tensiones adicionales sobre el cuerpo del mismo.

Es necesario verificar la correcta alineación de los ejes de entrada y salida con el motor de mando y con la máquina accionada (especialmente cuando se monta un par de engranajes o existe un apoyo externo).

Para una perfecta nivelación de la base, recomendamos usar suplementos de chapa, y solamente luego de verificada apretar firmemente los bulones de la base.

En los reductores que operan a la intemperie, es aconsejable proveer una cobertura protectora. Lo mismo es válido, cuando el ambiente es muy sucio o se está en presencia de salpicaduras de agua, radiación de calor, polvo, etc.

Cuando en el eje de salida se instale un mando a cadena o un par de engranajes, se deberá verificar que la dirección de la fuerza resultante esté dirigida preferentemente hacia la base, en caso contrario rogamos consultarnos. En los reductores con antiretroceso incorporado, se verificará previamente que el sentido de giro del motor eléctrico sea el que corresponde al marcado en el reductor.

PUESTA EN MARCHA

Se recomienda rodar el reductor en vacío durante un período de 2 / 3 hs., para luego proceder a aplicar la carga en forma gradual hasta la plena potencia. En ambas fases, controlar que el funcionamiento sea normal con ausencia de vibraciones, ruidos y temperaturas anormales. La temperatura del aceite puede llegar a 100°C en condiciones de temperatura del ambiente normal. Asimismo pueden aceptarse períodos breves con temperaturas de alrededor de 120°C. Se aconseja rodar con intervalos de 3/4 semanas, aquellos reductores que por razones de servicio, deban permanecer parados por largos períodos de tiempo (3 o más meses).

DELIVERY, HANDLING, INSTALLATION AND FIELD ASSEMBLY.

All speed reducers are factory inspected prior to shipping and compared to the customer purchase order for verification of proper match. They are tested during a run-in period for smooth operation, output speed, noise and temperature.

Normally, this model of speed reducer is delivered in standard cardboard packaging .

These speed reducers must be properly supported when removed from their packaging and during installation. Care must be taken when installing couplings or sprockets onto the shafts avoiding blows that can displace internal components from their correct relationships to each other.

The keyways exceed DIN 6885 section 1.

The shafts are prepared to a tolerance of iso k6 with our recommendation to use coupling parts that are to iso H7, and these should be axially locked with bolts.

The speed reducers must be securely installed on a solid and level base to ensure proper lubrication and not to subject the casing and components to any undue lateral or torsional stress.

Alignment of the input and output shafts to the driving motor and driven machine are critical for the performance and service life of the speed reducer.

The use of steel shims or plates is recommended to level the unit out and once this is done, to securely fasten down the speed reducer with appropriately sized bolts.

If the speed reducer is to operate outdoors or in a very dusty area, exposed to water spray or a radiating heat source, we recommend that some protection be put around the speed reducer. If you are unsure of your application conditions, please check with the factory.

Always install the output connections such that the output force is directed towards the base of the speed reducer.

In speed reducers that incorporate anti-reverse features (Backstop) ensure that the motor turns in the same direction as indicated on the speed reducer.

INITIAL START-UP

It is recommended to run-in the speed reducer without load for 2 or 3 hours during which time the unit should be checked for vibration and leaks. After this brief interval, the load should be gradually applied until the full load is on the speed reducer and the operation of the unit is confirmed to be smooth and quiet and that the operating temperature of the unit does not exceed recommended levels.

The operating temperature of the oil can reach 100 deg. C. in normal operating ambient and considered normal as well as brief operation up to 120 deg. C.

If the speed reducer needs to be out of operation for more than 3 months, Lentax recommends a brief period of operation every 3-4 weeks, with or without load, to keep a film of protective lubricant on the internal parts.

CAMBIO DE ACEITE

El primer cambio de aceite se deberá efectuar a las 20000 hs. de marcha en el caso de aceite sintético y a las 5000 hs en el caso de aceite con base mineral.

El drenaje del aceite se efectuará inmediatamente, evitando que se enfríe.

Recomendamos reponer o agregar lubricantes del mismo tipo y marca. Cuando se lo desee cambiar, se deberá realizar previamente un correcto lavado del reductor, evitando así la mezcla de diferentes clases.

El lubricante se carga a través de la tapa de inspección.

Vigilar que el nivel se encuentre dentro de los límites establecidos. Si es bajo, la lubricación será insuficiente. Si es alto se produce un calentamiento adicional por el batido, con pérdida de rendimiento y peligro de formación de espuma.

Verificar periódicamente el nivel de aceite, con el reductor parado y frío. Agregar si el nivel se encuentra por debajo de la marca inferior.

Los rodamientos no requieren lubricación adicional dado que la reciben por salpicado al escurrir el aceite hacia el cárter del reductor.

GARANTÍA

Todos los reductores gozan de una garantía de 1 año contra todo defecto de material y/o fabricación, calculada a partir de su fecha de entrega.

Durante ese período, se repondrá o se reparará sin cargo cualquier pieza que según nuestro exámen resulte con defectos de fabricación.

Para formalizar cualquier reclamo de garantía, el usuario deberá remitirnos sin desarmar el equipo a nuestra fábrica, con indicación de las condiciones de servicio y de la falla detectada.

No estarán incluidos dentro de la garantía los siguientes casos:

- 1) Falta de lubricante, o de tipo y/o calidad inapropiado.
- 2) Condiciones de servicio diferentes a las especificadas en el pedido.
- 3) Montaje inadecuado.
- 4) Cualquier otra aplicación no contemplada en el presente catálogo o expresamente autorizada por nuestro departamento técnico.

CORROSIÓN

Los reductores de velocidad Lentax no están garantizados contra daños producidos por corrosión .

RESPONSABILIDAD

Los datos técnicos contenidos en este catálogo están sujetos a modificaciones dimensionales o de diseño sin previo aviso. Quedando a criterio de Lentax la provisión o nó de los equipos de acuerdo a las presentes especificaciones.

OIL CHANGE

Lentax recommends the oil change every 20,000 hours of operation for units with synthetic oil and every 5,000 hours for units with mineral oil.

It is strongly recommended that you verify your choice of lubricating oil with Lentax if deviating from the recommended type.

We recommend to always top up the oil reservoir using the same type and grade of oil. If switching between standard and synthetic oils, it may be advisable to wash the oil chamber clean prior to adding the new type of oil.

WARRANTY

Lentax warrants to the purchaser of each new product that any part thereof which proves to be defective in material or workmanship under normal use within 18 months of the date of shipment, or 12 months from the date of start operation, (whichever occurs first) will be repaired or replaced without charge. Any such defect must be brought to the attention of the company's office from which the product was purchased, which is authorized to furnish repair or replacement within the terms of this warranty. The company will not be responsible for any expenses incurred in the installation, removal from service, transportation cost, or for damages of any type whatsoever, including incidental or consequential damages. Some states and provinces do not allow exclusion or limitation of incidental or consequential damages so the preceding exclusion or limitation may not apply to you.

Since Lentax cannot anticipate or control the conditions under which our products may be used, we accept no responsibility for the safety and suitability of our products when used alone or in combination with other products, tests for safety and suitability of the products should be done by the user.

This warranty will not apply, if in the judgement of the company, damage or failure has resulted from accident, alteration, misuse, abuse or operation in any way different than specified initially. The foregoing is in lieu of other warranties expressed or implied. Lentax neither assumes nor authorizes any person to assume for it any other obligation or liability in connection with said product.

Since the paint finish may be damaged in use, no warranty applies to such paint finish except for manufacturing defects which become apparent in the first 30 days of operation.

CORROSION

Speed reducers are not guaranteed against damage caused by corrosion.

LIABILITY

Technical data contained in this catalog is subject to change without notice. The company will endeavor to supply the equipment as illustrated, but reserves the right to make dimensional and other design changes as required.

SELECCIÓN DEL REDUCTOR	SELECTION OF THE GEARBOX
<p>INFORMACIÓN NECESARIA PARA LA CORRECTA SELECCIÓN</p>	<p>FOR THE CORRECT SELECTION IT IS NECESSARY TO KNOW</p>
<p>REDUCTOR</p> <ul style="list-style-type: none"> - Potencia de entrada - Velocidad de entrada - Momento útil necesario en el eje de salida - Velocidad de salida o relación de transmisión - Factor de servicio - Cargas externas sobre el eje de salida: RADIAL - AXIAL - Tipo de máquina a operar - Sobrecargas Indicar <ul style="list-style-type: none"> Duración Frecuencia - Forma de acoplamiento <ul style="list-style-type: none"> Con acople rígido Con manchón elástico Con engranaje Con cadena Con correas - Posición de montaje <p>MOTOR</p> <ul style="list-style-type: none"> - Potencia -Velocidad sincrónica - Voltaje - Frecuencia - Protección térmica Clase de aislación - Posición caja de conexiones - Temperatura ambiente (si es mayor de 40°C) - Altura sobre el nivel del mar (si es mayor de 1000 m). - Tiempo de funcionamiento - Arranque en vacío o bajo carga - Cantidad de arranques por hora - Tipo de arranque <ul style="list-style-type: none"> - Arranque directo - Arranque Indirecto - Estrella - Triángulo - Arrancador Suave - Variador de frecuencia - Si el motor es de 2 velocidades indicar - Velocidades de salida - Potencias necesarias en ambas velocidades - Si lleva freno especificar - Cupla de frenado - Ciclo de trabajo (arranques por hora) - Tiempo de funcionamiento - Inercias a frenar, trasladadas al eje del motor 	<p>GEARBOX</p> <ul style="list-style-type: none"> - <i>Input Power</i> - <i>Input Speed in R.P.M.</i> - <i>Output Torque</i> - <i>Output Speed in R.P.M., or Ratio</i> - <i>Service Factor</i> - <i>Overhung Loads : RADIAL - THRUST</i> - <i>Type of machine to operate</i> - <i>Overloads</i> <i>It is necessary to know</i> <ul style="list-style-type: none"> <i>Running time</i> <i>Frequency</i> - <i>Type of transmission between drive motor and gearbox</i> <ul style="list-style-type: none"> <i>Direct coupling</i> <i>Flexible coupling</i> <i>Pinion-Gear</i> <i>Sprocket-wheel chain</i> <i>Belt Drive</i> - <i>Mounting position</i> <p>DRIVE MOTOR</p> <ul style="list-style-type: none"> - <i>Power -Number of poles</i> - <i>Voltage - Frequency - Insulation class - Thermal protection</i> - <i>Position of the terminal box</i> - <i>Ambient Temperature (if higher than 40°C)</i> - <i>Altitude (if higher than 1000 m above sea level)</i> - <i>Running time</i> - <i>Mass to accelerate.</i> - <i>Number of starts and stops/hour</i> - <i>Kind of start</i> <ul style="list-style-type: none"> - <i>Direct start</i> - <i>Indirect Start</i> - <i>Star-Triangle</i> - <i>Soft Starter</i> - <i>Inverter ()</i> - <i>For double speed motors :</i> - <i>Output speeds</i> - <i>Both necessary input powers</i> - <i>For Brakemotors</i> - <i>Braking Torque</i> - <i>Number of starts and stops/hour</i> - <i>Running time</i> - <i>Inertia of the driven machine</i>

SELECCION DEL MOTOREDUCTOR

La selección se efectúa mediante el Listado de Potencias, velocidades y momentos útiles (pgs. 18...36) debiendo verificarse que el Factor de seguridad del equipo sea mayor ó igual que el Factor de Servicio requerido.

$$F_z > F_s$$

El Factor de servicio (F_s) depende del tiempo de servicio y las características de la carga, pudiendo determinarse del siguiente gráfico:

GEARMOTOR SELECTION

To select the appropriate gear unit consult the Selection Tables (pages 18...36) and must verify that the Safety Factor is equal or greater than the Service Factor.

$$F_z > F_s$$

Service Factor (F_s) depends on the running time and the load classification. It can be determined from the diagram below:

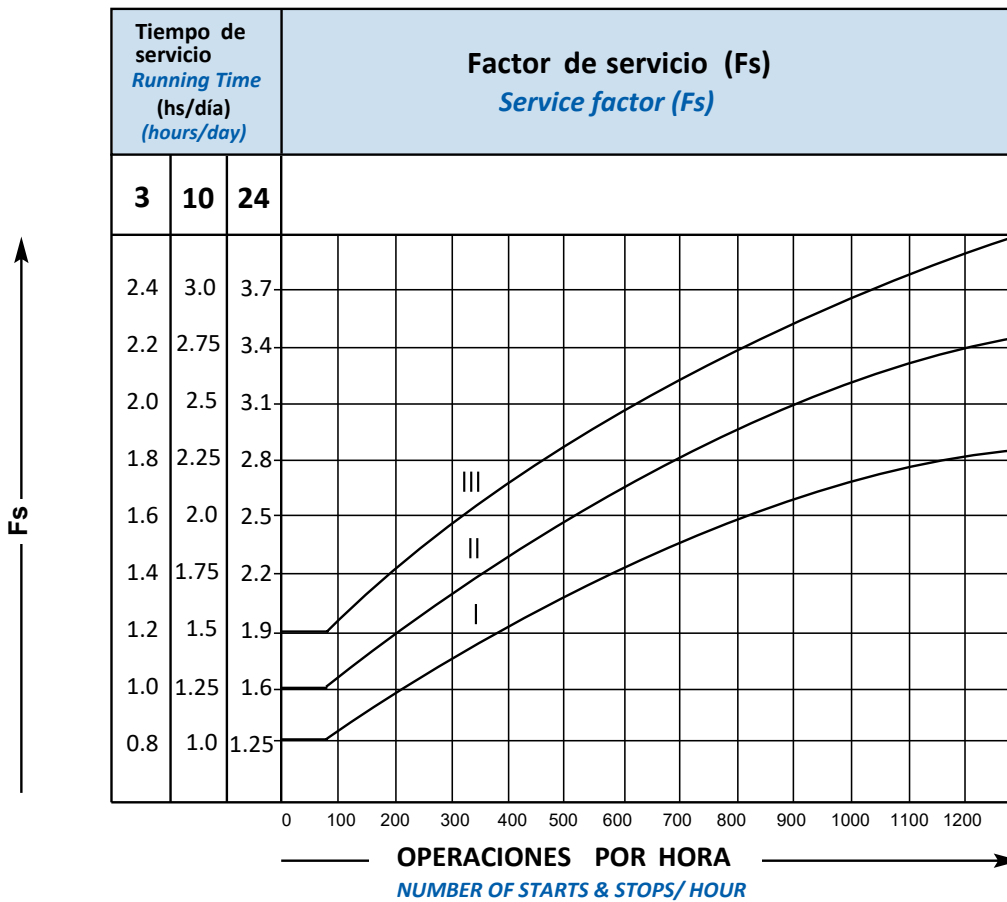

CARACTERISTICAS DE LA CARGA

LOAD CLASSIFICATION

- I REGULAR: Pequeñas masas para acelerar sin sobrecargas.
I UNIFORM LOAD: Small mass to accelerate, without overloads.
- II IRREGULAR: Medianas masas para acelerar sobrecargas medianas.
II MODERATE SHOCK LOAD: Medium mass to accelerate, moderate overloads.
- III IRREGULAR: Grandes masas para acelerar fuertes sobrecargas.
III HEAVY SHOCK LOAD: Large mass to accelerate, heavy overloads.

En las pags. 11, 12, 13 y 14 se ofrecen ejemplos típicos de aplicaciones y sus respectivos factores de servicio orientativos.

Please refer to pages 11, 12, 13 and 14 in order to help you to determinate the Service Factor.

MAQUINA ACCIONADA TIPO DE MAQUINA	FACTOR fs <i>fs FACTOR</i> hs. de Servicio <i>Service hrs.</i> 8 16 24			APPLICATIONS - INDUSTRY DRIVEN MACHINE
EXCAVADORAS Y DRAGAS Excavadoras de cangilones (cadena fija) Excavadoras de cangilones (cadena suelta) Traslación por orugas Traslación por rieles Bombas de aspiración Apiladoras de cangilones Ruedas de cangilones Cabezales de corte Dispositivo de viraje	1.65 1.8 1.8 1.5 1.6 1.6 1.65 1.8 1.8 1.5 1.6 1.6 1.4 1.5 1.6 1.4 1.5 1.6 1.65 1.8 1.8 1.65 1.8 1.8 1.65 1.8 1.8	DREDGERS <i>Bucket excavator</i> <i>Trench machine</i> <i>Travelling gear (caterpillar)</i> <i>Travelling gear (rails)</i> <i>Suction pumps</i> <i>Bucket loader</i> <i>Bucket wheels</i> <i>Cutter heads</i> <i>Manoeuvring winches</i>		
TRITURACION Y MOLIENDA (cemento-cal-yeso) Trituradoras de mandíbulas Trituradoras de cono Trituradoras rotativas Quebrantadoras rotativas Hornos rotativos Sopladores Zarandas vibratorias Molinos de martillos Molinos de bolas Molinos de percusión Molinos tubulares Machacadoras	1.65 1.8 1.8 1.65 1.8 1.8 1.65 1.8 1.8 1.65 1.8 1.8 1.8 2 2 1.4 1.5 1.5 1.5 1.6 1.6 1.8 2 2 1.65 1.8 1.8 1.9 2.1 2.1 1.8 2 2 1.8 2 2	STONE AND CLAY WORKING MACHINES <i>Jaw crushers</i> <i>Cone crushers</i> <i>Gyratory crushers</i> <i>Rotary breakers</i> <i>Rotary ovens</i> <i>Blowers</i> <i>Vibrating screens</i> <i>Hammer mills</i> <i>Ball mills</i> <i>Beater mills</i> <i>Tube mills</i> <i>Breakers</i>		
MAQUINAS PARA EL CAUCHO Calandras Amasadoras Extrusoras Laminadoras Mezcladoras	1.5 1.6 1.6 1.65 1.8 1.8 1.65 1.8 1.8 1.65 1.8 1.8 1.5 1.6 1.6	RUBBER MACHINERY <i>Calenders</i> <i>Pugmills</i> <i>Extruders</i> <i>Rolling mills</i> <i>Mixers</i>		
TRANSPORTE Y ALMACENAJE Montacargas Elevadores de personas Elevadores inclinados Elevadores de cangilones (rocas) Elevadores de cangilones (granos) Transportadores a cadena (redlers) Transportadores de cangilones Transportadores circulares Roscas transportadoras Bandas transportadoras (granel) Transportadores de banda (articulados) Transportadores de cinta de acero Bandas transportadoras (bultos grandes) Transportadores de placas Tornos de elevación	1.5 1.6 1.6 1.8 2.0 2.0 1.65 1.8 1.8 1.65 1.8 1.8 1.5 1.6 1.6 1.5 1.6 1.6 1.5 1.6 1.6 1.5 1.6 1.6 1.15 1.4 1.5 1.15 1.4 1.5 1.3 1.5 1.7 1.5 1.6 1.6 1.3 1.5 1.7 1.5 1.6 1.6 1.5 1.6 1.6	CONVEYORS <i>Hoists</i> <i>Passenger lifts</i> <i>Inclined hoists</i> <i>Bucket elevators (piece goods)</i> <i>Bucket elevators (bulk material)</i> <i>Chain conveyors</i> <i>Bucket conveyors</i> <i>Circular conveyors</i> <i>Screw conveyors</i> <i>Belt conveyors (bulk material)</i> <i>Apron conveyors</i> <i>Steel belt conveyors</i> <i>Belt conveyors (piece goods)</i> <i>Band pocket conveyors</i> <i>Ballast elevators</i>		

MAQUINA ACCIONADA TIPO DE MAQUINA	FACTOR fs <i>fs FACTOR</i> hs. de Servicio <i>Service hrs.</i> 8 16 24			APPLICATIONS - INDUSTRY DRIVEN MACHINE
VENTILADORES - SOPLADORES Ventiladores (axiales y radiales) Turboventiladores Sopladores rotativos a pistón Ventiladores de torres de enfriamiento Ventiladores de Aspiración	1 1.2 1.4 1 1.2 1.4 1.2 1.4 1.5 1.5 1.6 1.6 1 1.3 1.5	BLOWERS - VENTILATORS <i>Blowers (axial and radial)</i> <i>Turbo blowers</i> <i>Rotary piston blowers</i> <i>Cooling tower fans</i> <i>Induced draught fans</i>		
ALIMENTACION Y AZUCAR Amasadoras Cortadoras de caña de azúcar Desmenuzadoras de remolacha Lavadoras de remolacha Llenadoras de botellas Machacadoras de caña de azúcar Máquinas empaquetadoras Molinos para caña de azúcar Recipientes para macerar	1.5 1.6 1.7 1.6 1.7 1.8 1.5 1.6 1.7 1.4 1.5 1.6 1.15 1.4 1.5 1.5 1.6 1.7 1.15 1.4 1.5 1.65 1.8 1.8 1.5 1.6 1.7	FOOD INDUSTRY MACHINERY <i>Kneading machines</i> <i>Cane knives</i> <i>Sugar beet cutters</i> <i>Sugar beet washing machines</i> <i>Bottling and container filling</i> <i>Cane crushers</i> <i>Packaging machines</i> <i>Cane mills</i> <i>Mash tubes , crystallizers</i>		
BOMBAS Bombas centrífugas (líquidos) Bombas centrífugas (semilíquidos) Bombas de émbolo (U 1 : 100-200) Bombas de émbolo (U < 100) Bombas de presión	1.2 1.3 1.4 1.3 1.4 1.5 1.6 1.8 1.8 1.8 1.8 2 1.6 1.8 1.8	PUMPS <i>Centrifugal pumps (light-liquids)</i> <i>Centrifugal pumps (semi-liquids)</i> <i>Piston pumps</i> <i>Plunger pumps</i> <i>Pressure pumps</i>		
SIDERURGIA Y LAMINACION Sopladores de Alto horno Mando de Convertidores basculantes Cargadores inclinados de alto horno Rodillos de transporte (uso pesado) Rodillos de transporte (uso liviano) Ajuste de Cilindros Arrastradores transversales Cizallas Empujadores de lingotes Enderezadores de rodillos Enrolladores (chapa o alambre) Laminadores (chapa fina o gruesa) Laminadores de palanquilla Laminadores en frío Máquinas para soldar tubos Tijeras de palanquilla Tijeras de rebordear Mecanismos de desplazamiento Transportadores de palanquilla Trefiladoras Trituradores de Escoria Volteadoras de chapa Enderezadora y Cortadora Continua	1.4 1.4 1.4 1.8 1.8 1.8 1.8 1.8 1.8 1.65 1.8 1.8 1.5 1.6 1.6 1.5 1.6 1.6 1.5 1.6 1.6 1.65 1.8 1.8 1.65 1.8 1.8 1.65 1.8 1.8 1.65 1.8 1.8 1.65 1.8 1.8 1.65 1.8 1.8 1.65 1.8 1.8 1.65 1.8 1.8 1.65 1.8 1.8 1.65 1.8 1.8 1.65 1.8 1.8 1.5 1.6 1.6 1.5 1.6 1.6 1.5 1.6 1.6	METAL ROLLING MILLS <i>Cooling beds</i> <i>Continuous casting plant</i> <i>Manipulators</i> <i>Roller tables (heavy)</i> <i>Roller tables (light)</i> <i>Roller adjustment drives</i> <i>Cross transfers</i> <i>Trimming shears</i> <i>Ingot pushers</i> <i>Roller straighteners</i> <i>Winding machines (strip and wire)</i> <i>Heavy and medium plate mills</i> <i>Ingot and blooming mills</i> <i>Cold rolling mills</i> <i>Tube welding machine</i> <i>Billet shears</i> <i>Cropping shears</i> <i>Chain transfers</i> <i>Ingot handling machinery</i> <i>Wire drawing benches</i> <i>Sheet mills,descaling machines</i> <i>Plate tilters</i> <i>Plate shears</i>		

MAQUINA ACCIONADA TIPO DE MAQUINA	FACTOR fs <i>fs FACTOR</i> hs. de Servicio <i>Service hrs.</i> 8 16 24			APPLICATIONS - INDUSTRY DRIVEN MACHINE
MAQUINAS PARA PLASTICOS Calandras Extrusoras Desmenuzadoras Mezcladoras	1.5 1.6 1.6 1.65 1.8 1.8 1.5 1.6 1.6 1.65 1.8 1.8	PLASTIC INDUSTRY MACHINERY <i>Calenders</i> <i>Extruders</i> <i>Crushers</i> <i>Mixers</i>		
MAQUINAS PARA TRABAJAR METALES Máquinas dobladoras Enderezadoras de chapas Balancines Cizallas Prensas de forja Prensas de estampado Mandos principales de máquinas herramientas Mandos secundarios de máquinas herramientas Cepillos	1.5 1.6 1.6 1.65 1.8 1.8 1.65 1.8 1.8 1.5 1.6 1.6 1.65 1.8 1.8 1.5 1.6 1.6 1.15 1.4 1.5 1.65 1.8 1.8	METAL WORKING MACHINE <i>Sheet metal bending machines</i> <i>Plate straightening machines</i> <i>Punch presses</i> <i>Shears</i> <i>Forging presses</i> <i>Stamping presses</i> <i>Machine tools, main drives.</i> <i>Machine tools, auxiliary drives.</i> <i>Metal planing machines</i>		
GRUAS Mecanismo de elevación Mecanismo de Giro Mecanismo de Traslación Mando de Pluma articulada	1.3 1.5 1.6 1.5 1.6 1.6 1.65 1.8 1.8 1.5 1.6 1.6	CRANES <i>Luffing gear</i> <i>Bull gear</i> <i>Travelling gear</i> <i>Derricking jib gear</i>		
INDUSTRIA ACEITERA Filtros Prensa Bombas de línea Bombas de barrido	1.5 1.6 1.6 1.5 1.6 1.6 1.5 1.6 1.6	OIL INDUSTRY <i>Filter press</i> <i>Pipeline pumps</i> <i>Scavenge pump</i>		
MAQUINAS PARA LA INDUSTRIA DEL PAPEL Calandras Cilindros laminadores Cilindros secadores Desfibradores de madera Deshilachadoras Lisas Molinos de pasta Prensas de deshidratación Prensas de vacío Prensas húmedas Encoladoras	1.4 1.5 1.6 1.65 1.8 1.8 1.65 1.8 1.8 1.65 1.8 1.8 1.65 1.8 1.8 1.65 1.8 1.8 1.5 1.6 1.6 1.65 1.8 1.8 1.65 1.8 1.8 1.65 1.8 1.8 1.8 2 2	PAPER MACHINES <i>Calenders</i> <i>Glazing cylinders</i> <i>Drying cylinders</i> <i>Shredders</i> <i>Pulpers</i> <i>Couches</i> <i>Pulp grinders</i> <i>Suction rolls</i> <i>Suction presses</i> <i>Wet presses</i> <i>Gluing machines</i>		
PRENSAS Prensas para plegado Prensas para briquetas Prensas excéntricas Prensas para forja Prensas para ladrillos	1.65 1.8 1.8 1.65 1.8 1.8 1.65 1.8 1.8 1.65 1.8 1.8 1.65 1.8 1.8	PRESSES <i>Bending presses</i> <i>Briqueting press</i> <i>Cam presses</i> <i>Forge presses</i> <i>Brick presses</i>		

MAQUINA ACCIONADA TIPO DE MAQUINA	FACTOR fs <i>fs FACTOR</i> hs. de Servicio <i>Service hrs.</i> 8 16 24			APPLICATIONS - INDUSTRY DRIVEN MACHINE
MAQUINAS PARA INDUSTRIA TEXTIL Máquinas bobinadoras Máquinas de tinte y estampado Máquinas secadoras Tinas para curtido Máquinas cortadoras Telares COMPRESORES Compresores de émbolo (U 1 : 100-200) Compresores de émbolo (U < 100) Turbo compresores TRATAMIENTO DE AGUAS Aireadores Tornillo de Arquímedes PETROLEO (EXPLORACION Y TRANSPORTE) Bombas de oleoductos Instalaciones de perforación MAQUINARIA PARA LA CONSTRUCCION Elevadores de carga Mezcladoras de hormigón Transportadores INDUSTRIA QUIMICA Agitadores (livianos - baja densidad) Agitadores (pesados - alta densidad) Centrífugas (uso liviano) Centrífugas (uso pensado) Mezcladoras Tambores de refrigeración Tambores secadores MAQUINAS PARA INDUSTRIA MADERERA Cepillos Descortezadores Sierras Alternativas Ensambladoras GENERADORES -CONVERTIDORES Convertidores de frecuencia Generadores Generadores para soldaduras	1.15 1.4 1.5 1.3 1.4 1.5 1.3 1.4 1.5 1.3 1.4 1.6 1.3 1.4 1.5 1.15 1.4 1.5 1.6 1.7 1.8 1.7 1.8 2 1.6 1.7 1.8 1.5 1.5 1.5 1.15 1.4 1.5 1.4 1.5 1.6 1.65 1.8 1.8 1.5 1.6 1.7 1.6 1.7 1.8 1.4 1.5 1.6 1.15 1.4 1.5 1.3 1.5 1.7 1.15 1.4 1.5 1.3 1.5 1.7 1.5 1.6 1.6 1.5 1.6 1.6 1.5 1.6 1.6 1.5 1.6 1.6 1.65 1.8 1.8 1.65 1.8 1.8 1.2 1.3 1.4 1.65 1.8 1.8 1.15 1.4 1.5 1.6 1.7 1.8	TEXTILE MACHINES <i>Batchers</i> <i>Printing and dyeing machines</i> <i>Willows</i> <i>Tanning vats</i> <i>Cutters</i> <i>Looms</i> COMPRESSORS <i>Piston compressors (U1 : 100-200)</i> <i>Piston compressors (U < 100)</i> <i>Turbo compressors</i> WATER TREATMENT <i>Aerators</i> <i>Screw pumps</i> PETROLEUM INDUSTRY <i>Pipeline pumps</i> <i>Rotary drilling equipment</i> BUILDING MACHINERY <i>Hoists</i> <i>Concrete mixers</i> <i>Road construction machinery</i> CHEMICAL INDUSTRY <i>Agitators (liquid material)</i> <i>Agitators (semi-liquid material)</i> <i>Centrifuges (heavy)</i> <i>Centrifuges (light)</i> <i>Mixers</i> <i>Cooling drums</i> <i>Drying drums</i> WOOD WORKING MACHINES <i>Planing machines</i> <i>Barkers</i> <i>Saw frames</i> <i>Wood working machine</i> GENERATORS - TRANSFORMERS <i>Frequency transformers</i> <i>Generators</i> <i>Welding generators</i>		

CARGAS RADIALES

Normalmente se recomienda acoplar los reductores de potencias medias y grandes, directamente con manchones elásticos. Cuando ello no sea posible, solicitamos consultarnos, indicándonos el valor, punto de aplicación y orientación de dichas cargas.

CALCULO DE LA CARGA RADIAL

La carga radial provocada por un elemento de transmisión puede calcularse con:

$$Pr = \frac{M \cdot k \cdot k1 \cdot f}{10 Dp/2} \quad [\text{da N}]$$

M= Momento torsor necesario en el eje de salida (Nm)

Dp= Diametro primitivo del elemento de reduccion aplicado en el eje de salida (m).

k= Constante según el tipo de reducción.

k= 1.0 engranajes

k= 1.4 piñón y cadena

k= 1.8 correas en V

k= 2.2 correas planas

k1= Constante según el tipo de construcción.

k1= 1.0 en equipo standard

k1= 0.7 en equipo con trompa para agitador.
(RU, AG sobre pedido, consultarnos)

f = factor de corrección para el caso de carga aplicada fuera del centro del extremo de eje standard.

Siendo $f = 1 + \frac{e}{L}$

Donde:

e = distancia del punto de aplicación al centro del eje (m).

L= ver tabla (pag.16)

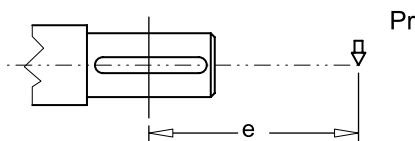

En todo caso debera verificarse que :

$$Pr < P \text{ adm}$$

Caso contrario, deberá incrementarse el diámetro del elemento de transmisión o adoptarse una caja reductora de mayor capacidad.

En casos de servicios severos rogamos consultarnos.

RADIAL LOADS

We normally recommend that medium to high H.P. speed reducers be connected to the driven machine by means of flexible coupling.

When the use of couplings is not posible, please consult the factory providing us with details of the application and the orientation that the shafts will have to each other.

CALCULATION OF RADIAL LOADS

The radial load can be calculated using the following formula:

$$Pr = \frac{M \cdot k \cdot k1 \cdot f}{Dp/2} \quad [\text{lb}]$$

M= Output torque (lb-inch).

Dp= Pitch diameter of driven pulley, gear, pinion. (inch)

k= Load connection factor.

k= 1.0 gear

k= 1.4 sprocket-wheel chain.

k= 1.8 V-belt

k= 2.2 Flat belt

k1= building factor

k1= 1.0 in standard unit

k1= 0.7 in agitator unit
(RU, AG under request, please consult us)

f = load location factor

To determinate the load location factor apply the following formula.

$$f = 1 + \frac{e}{L}$$

Where:

e = distance from center line of load to midpoint of output shaft.

L = see table on page 16

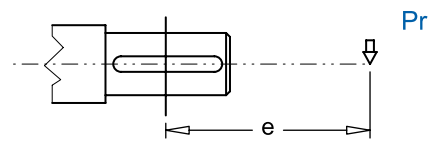

Each case must verify that :

$$Pr < P \text{ adm}$$

Otherwise, the pitch diameter of driven pulley should be increased, or choose the next size up speed reducer. Anyway, on heavy duty service, check with our technical support.

CARGAS RADIALES Y AXIALES ADMISIBLES EN EL EJE DE SALIDA* OUTPUT SHAFT OVERHUNG LOAD RATING*

CARGAS RADIALES Y AXIALES ADMISIBLES PARA EJE DE SALIDA HUECO HOLLOW SHAFT OVERHUNG LOAD RATING

MODELO MODEL		VELOCIDAD EN EL EJE DE SALIDA (r.p.m.) / OUTPUT SPEED (r.p.m.)							
		...< 5	5...20	21...40	41...60	61...80	81...120	121...150	151...250
KL2	Carga radial (daN) Radial load	2100	1960	1880	1680	1460	1150	1050	915
	Carga axial (daN) Thrust	840	784	752	672	584	460	420	366
KL3	Carga radial (daN) Radial load	3200	3000	2860	2560	2220	1740	1610	1280
	Carga axial (daN) Thrust	1280	1200	1144	1024	888	696	644	512
KL4	Carga radial (daN) Radial load	4500	4220	4020	3600	3120	2450	2260	1520
	Carga axial (daN) Thrust	1800	1688	1608	1440	1248	980	904	608
KL45	Carga radial (daN) Radial load	7200	7070	5840	4930	4070	3520	3140	2275
	Carga axial (daN) Thrust	2880	2828	2336	1972	1628	1408	1256	910
KL5	Carga radial (daN) Radial load	9500	9500	9470	7410	6090	5090	4430	3220
	Carga axial (daN) Thrust	3800	3800	3788	2964	2436	2036	1772	1288

Nota 1*: Validas para cargas aplicadas en el centro de la punta de eje.

Note 1: For loads applied on the middle of the end shaft.*

Nota 2: Validas para reductor sometido a Potencia Nominal , otros casos consultarnos.

Note 2: For gearbox working at full Nominal Power, otherwise check with the factory.

Nota 3: Para solicitudes mayores consulte nuestro Depto Técnico.

Note 3: Please consult LENTAX regarding larger overhung load requirements.

CARGAS ADMISIBLES MÁXIMAS PARA EJE DE SALIDA MACIZO STANDARD* OUTPUT SHAFT OVERHUNG LOAD RATING*

* ADOPTAR EL MENOR VALOR DE LOS OBTENIDOS EN LAS DOS TABLAS.

** SELECT DE LOWER VALUE FROM THE TWO TABLES*

MODELO MODEL	KL2	KL3	KL4	KL45	KL5
Carga radial (daN) Radial load	2100	3200	4200	7000	8800

Nota 1*: Validas para cargas aplicadas en el centro de la punta de eje.

Note 1: For loads applied on the middle of the end shaft.*

Nota 2: Validas para reductor sometido a Potencia Nominal , y material del eje standard, otros casos consultarnos.

Note 2: For gearbox working at full Nominal Power, and factory standard material, otherwise check with the factory.

Nota 3: Para solicitudes mayores consulte nuestro Depto Técnico.

Note 3: Please consult LENTAX regarding larger overhung load requirements.

TABLA PARA DETERMINAR "L" TO DETERMINATE "L" SEE THE FOLLOWING TABLE

MODELO MODEL	KL2	KL3	KL4	KL45	KL5
L mm	120	140	175	210	256

CODIGO DE DESIGNACIÓN / UNIT DESIGNATIONS

Cada unidad se subdivide en 5 campos con sus correspondientes siglas o números. Juntando éstos se obtiene el código de designación del equipo.

Every unit contains 5 fields composed by characters or numbers. Joining these items we obtain the unit designation code.

Ejemplo: **KL3 - 400/6 FRB - 14.3 - H1A - XXX**

In example

KL3	400/6 FRB	14.3	H1A	XXX
① MODELO <i>MODEL</i>	② MOTOR <i>MOTOR</i>	③ VELOCIDAD <i>OUTPUT R.P.M.</i>	④ MONTAJE <i>MOUNTING POSITION</i>	⑤ KIT <i>KIT</i>
① MODELO <i>MODEL</i>	EJECUCION <i>UNIT TYPE</i>	R: Reductor / <i>Reducer</i> MR: Motoreductor sin motor de fabrica / <i>Gearbox with motor flange</i>		
	TAMAÑO <i>UNIT SIZE</i>	KL3 - KL4 - KL45		
② MOTOR <i>MOTOR</i>	Con motor = Potencia (HP) x 100 N° polos-Adicionales (1) <i>With motor = Nominal power (HP) x 100 pole quantity-Additional (1)</i> Sin motor = Tamaño carcasa <i>Without motor = Frame size</i>			
	(1) Adicionales : VFE: Ventilacion forzada <i>(1) Additional: With fan cooler</i>	Tr: Traba antiretroceso <i>Backstop</i>	Trl: Traba ruleman <i>Bearing backstop</i>	
	Fv / FRB: Motor con freno <i>Brakemotor</i>	CC: Corriente Continua <i>Direct current</i>	Ex-d: Antiexplosivo <i>Ex-d motor</i>	
③ VELOCIDAD <i>OUTPUT R.P.M.</i>	Para motoreductor se designa la velocidad de salida en R.P.M. <i>For gearmotor output speed in R.P.M.</i> Para reductor o con motor provisto por el cliente se designa la RELACION <i>For gearbox or motor-flange RATIO</i>			
④ MONTAJE <i>MOUNTING POSITION</i>	EJECUCION <i>MOUNTING TYPE</i>	Eje sólido <i>solid shaft</i>	con patas / <i>foot mounted</i> (1a...6a, 1b...6b, 1ab...6ab) con brida / <i>flange mounted</i> (B1a...B6a, B1b...B6b)	
		Eje hueco <i>hollow shaft</i>	con patas / <i>foot mounted</i> (H1a...H6a, H1b...H6b) con brida / <i>flange mounted</i> (BH1a...BH6a, BH1b...BH6b)	
	POSICIONES <i>POSITION</i>	Orientación de salida <i>Output orientation</i>	horizontal / <i>horizontal</i> (1,3,5,6) vertical / <i>vertical</i> (2,4)	Más detalles ver pag.50 <i>More details see page.50</i>
⑤ KIT <i>KIT</i>	Segun sus necesidades, los equipos son provistos de : <i>Under request the gearboxes could be provide of :</i> RU, AG: Trompa para agitador / <i>Turret for agitator</i> XXX: Ejecuciones especiales / <i>Special designs</i> (p/ejemplo: eje de salida especial) / <i>(i.e.: special output shaft)</i>			

Ejemplo: **KL3 - 400/6 FRB - 14.3 - H1A - XXX**

Example

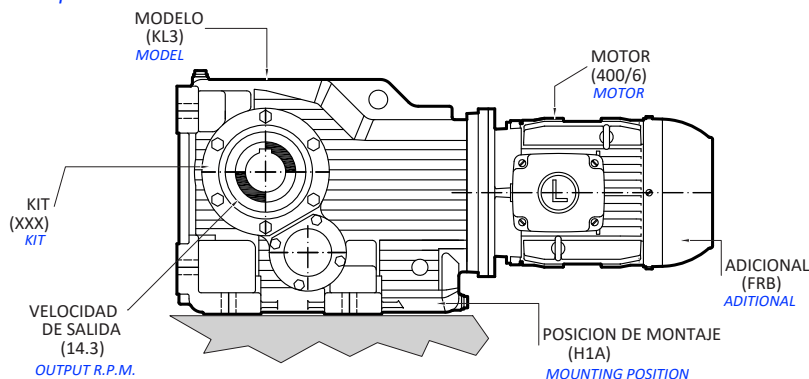

Potencia Entrada		Velocidad Salida aprox.	Relación	MODELO		Factor de Seguridad	Momento Util	Velocidad Entrada aprox.	Carga Radial adm.	Carga Axial adm.	Peso aprox.	Medidas	Repuestos
kW	HP	(RPM)	(i)			(fz)	(Nm)	(RPM)	(kg)	(kg)	(kg)	Página	Página
0,75 kW	1,00 HP	2,0	696,69	KL45HR	1,00	2,35	3326	1410	7200	2880	361	39-40	51
		2,6	544,56	KL45HR	1,00	3,00	2600	1410	7200	2880	361	39-40	51
		3,2	440,48	KL45HR	1,00	3,70	2103	1410	7200	2880	361	39-40	51
		1,8	804,35	KL4TR	1,00	1,15	3841	1410	4500	1800	242	39-40	51
		2,2	631,51	KL4TR	1,00	1,50	3015	1410	4500	1800	242	39-40	51
		2,7	513,24	KL4TR	1,00	1,85	2451	1410	4500	1800	242	39-40	51
		3,3	427,23	KL4TR	1,00	2,20	2040	1410	4500	1800	242	39-40	51
		3,9	361,87	KL4TR	1,00	2,60	1728	1410	4500	1800	242	39-40	51
		4,5	310,51	KL4TR	1,00	3,05	1483	1410	4500	1800	242	39-40	51
		5,2	269,09	KL4TR	1,00	3,50	1285	1410	4220	1688	242	39-40	51
		5,7	247,86	KL4TR	1,00	3,80	1183	1410	4220	1688	242	39-40	51
		2,0	722,47	KL3TR	1,00	0,95	3450	1410	3200	1280	171	39-40	51
		2,5	567,22	KL3TR	1,00	1,20	2708	1410	3200	1280	171	39-40	51
		3,1	460,99	KL3TR	1,00	1,45	2201	1410	3200	1280	171	39-40	51
		3,7	383,74	KL3TR	1,00	1,75	1832	1410	3200	1280	171	39-40	51
		4,3	325,03	KL3TR	1,00	2,05	1552	1410	3200	1280	171	39-40	51
		5,1	278,90	KL3TR	1,00	2,40	1332	1410	3000	1200	171	39-40	51
		5,8	241,69	KL3TR	1,00	2,75	1154	1410	3000	1200	171	39-40	51
		6,6	215,18	KL3TR	1,00	3,10	1027	1410	3000	1200	171	39-40	51
		8,1	174,88	KL3TR	1,00	3,85	835	1410	3000	1200	171	39-40	51
		4,2	335,13	KL2TR	1,00	1,00	1600	1410	2100	840	111	39-40	51
		4,9	287,57	KL2TR	1,00	1,10	1373	1410	2100	840	111	39-40	51
		5,7	249,21	KL2TR	1,00	1,35	1190	1410	1960	784	111	39-40	51
		6,6	213,35	KL2TR	1,00	1,55	1019	1410	1960	784	111	39-40	51
		8,1	173,40	KL2TR	1,00	1,95	828	1410	1960	784	111	39-40	51
		9,8	144,34	KL2TR	1,00	2,30	689	1410	1960	784	111	39-40	51
		11,5	122,25	KL2TR	1,00	2,75	584	1410	1960	784	111	39-40	51

Potencia Entrada		Velocidad Salida aprox.	Relación	MODELO		Factor de Seguridad	Momento Util	Velocidad Entrada aprox.	Carga Radial adm.	Carga Axial adm.	Peso aprox.	Medidas	Repuestos
kW	HP	(RPM)	(i)			(fz)	(Nm)	(RPM)	(kg)	(kg)	(kg)	Página	Página
0,75 kW	1,00 HP	13,4	104,90	KL2TR	1,00	3,20	501	1410	1960	784	111	39-40	51
		15,5	90,91	KL2TR	1,00	3,70	434	1410	1960	784	111	39-40	51
		8,5	108,81	KL2	1,00 /6	2,10	809	920	1960	784	103	37-38	51
		10,9	84,62	KL2	1,00 /6	2,70	629	920	1960	784	103	37-38	51
		13,5	68,07	KL2	1,00 /6	3,35	506	920	1960	784	103	37-38	51
		13,0	108,81	KL2	1,00	3,15	528	1410	1960	784	96	37-38	51

Potencia Entrada		Velocidad Salida aprox.	Relación	MODELO		Factor de Seguridad	Momento Util	Velocidad Entrada aprox.	Carga Radial adm.	Carga Axial adm.	Peso aprox.	Medidas	Repuestos
kW	HP	(RPM)	(i)			(fz)	(Nm)	(RPM)	(kg)	(kg)	(kg)	Página	Página
1,10 kW	1,50 HP	2,3	622,34	KL5HR	1,50	3,10	4395	1430	9500	3800	560	39-40	51
		2,9	486,45	KL5HR	1,50	3,95	3435	1430	9500	3800	560	39-40	51
		2,1	696,69	KL45HR	1,50	1,55	4920	1430	7200	2880	365	39-40	51
		2,6	544,56	KL45HR	1,50	2,00	3846	1430	7200	2880	365	39-40	51
		3,2	440,48	KL45HR	1,50	2,45	3111	1430	7200	2880	365	39-40	51
		3,9	362,28	KL45HR	1,50	3,00	2558	1430	7200	2880	365	39-40	51
		5,0	283,17	KL45HR	1,50	3,85	2000	1430	7070	2828	365	39-40	51
		2,3	631,51	KL4TR	1,50	1,00	4460	1430	4500	1800	246	39-40	51
		2,8	513,24	KL4TR	1,50	1,20	3624	1430	4500	1800	246	39-40	51
		3,3	427,23	KL4TR	1,50	1,45	3017	1430	4500	1800	246	39-40	51
		4,0	361,87	KL4TR	1,50	1,75	2555	1430	4500	1800	246	39-40	51
		4,6	310,51	KL4TR	1,50	2,00	2193	1430	4500	1800	246	39-40	51
		5,3	269,09	KL4TR	1,50	2,35	1900	1430	4220	1688	246	39-40	51
		5,8	247,86	KL4TR	1,50	2,55	1750	1430	4220	1688	246	39-40	51
		7,1	201,44	KL4TR	1,50	3,10	1423	1430	4220	1688	246	39-40	51
		8,5	167,69	KL4TR	1,50	3,75	1184	1430	4220	1688	246	39-40	51
		7,9	117,49	KL4	1,50 /6	3,65	1303	925	4220	1688	238	37-38	51
		3,1	460,99	KL3TR	1,50	0,95	3255	1430	3200	1280	175	39-40	51
		3,7	383,74	KL3TR	1,50	1,15	2710	1430	3200	1280	175	39-40	51
		4,4	325,03	KL3TR	1,50	1,35	2295	1430	3200	1280	175	39-40	51
		5,1	278,90	KL3TR	1,50	1,60	1970	1430	3000	1200	175	39-40	51
		5,9	241,69	KL3TR	1,50	1,85	1707	1430	3000	1200	175	39-40	51
		6,6	215,18	KL3TR	1,50	2,10	1520	1430	3000	1200	175	39-40	51
		8,2	174,88	KL3TR	1,50	2,55	1235	1430	3000	1200	175	39-40	51
		9,8	145,57	KL3TR	1,50	3,05	1028	1430	3000	1200	175	39-40	51
		11,6	123,30	KL3TR	1,50	3,60	871	1430	3000	1200	175	39-40	51

Potencia Entrada		Velocidad Salida aprox.	Relación	MODELO		Factor de Seguridad	Momento Util	Velocidad Entrada aprox.	Carga Radial adm.	Carga Axial adm.	Peso aprox.	Medidas	Repuestos
kW	HP	(RPM)	(i)			(fz)	(Nm)	(RPM)	(kg)	(kg)	(kg)	Página	Página
1,10 kW	1,50 HP	8,8	105,53	KL3	1,50 /6	2,85	1170	925	3000	1200	167	37-38	51
		11,2	82,61	KL3	1,50 /6	3,60	916	925	3000	1200	167	37-38	51
		6,7	213,35	KL2TR	1,50	1,05	1507	1430	1960	784	115	39-40	51
		8,2	173,40	KL2TR	1,50	1,30	1224	1430	1960	784	115	39-40	51
		9,9	144,34	KL2TR	1,50	1,55	1019	1430	1960	784	115	39-40	51
		11,7	122,25	KL2TR	1,50	1,85	863	1430	1960	784	115	39-40	51
		13,6	104,90	KL2TR	1,50	2,15	741	1430	1960	784	115	39-40	51
		15,7	90,91	KL2TR	1,50	2,45	642	1430	1960	784	115	39-40	51
		8,5	108,81	KL2	1,50 /6	1,40	1207	925	1960	784	107	37-38	51
		10,9	84,62	KL2	1,50 /6	1,80	939	925	1960	784	107	37-38	51
		13,6	68,07	KL2	1,50 /6	2,25	755	925	1960	784	107	37-38	51
		13,0	108,81	KL2	1,50	2,10	781	1430	1960	784	100	37-38	51
		17,0	84,62	KL2	1,50	2,70	607	1430	1960	784	100	37-38	51
		21,0	68,07	KL2	1,50	3,35	488	1430	1960	784	100	37-38	51

Potencia Entrada		Velocidad Salida aprox.	Relación	MODELO		Factor de Seguridad	Momento Util	Velocidad Entrada aprox.	Carga Radial adm.	Carga Axial adm.	Peso aprox.	Medidas	Repuestos
kW	HP	(RPM)	(i)			(fz)	(Nm)	(RPM)	(kg)	(kg)	(kg)	Página	Página
1,50 kW	2,00 HP	2,3	622,34	KL5HR	2,00	2,30	5943	1410	9500	3800	562	39-40	51
		2,9	486,45	KL5HR	2,00	2,95	4645	1410	9500	3800	562	39-40	51
		3,6	393,47	KL5HR	2,00	3,65	3757	1410	9500	3800	562	39-40	51
		2,0	696,69	KL45HR	2,00	1,15	6653	1410	7200	2880	367	39-40	51
		2,6	544,56	KL45HR	2,00	1,50	5200	1410	7200	2880	367	39-40	51
		3,2	440,48	KL45HR	2,00	1,85	4206	1410	7200	2880	367	39-40	51
		3,9	362,28	KL45HR	2,00	2,25	3460	1410	7200	2880	367	39-40	51
		5,0	283,17	KL45HR	2,00	2,90	2704	1410	7070	2828	367	39-40	51
		6,2	229,05	KL45HR	2,00	3,55	2187	1410	7070	2828	367	39-40	51
		3,3	427,23	KL4TR	2,00	1,10	4080	1410	4500	1800	248	39-40	51
		3,9	361,87	KL4TR	2,00	1,30	3456	1410	4500	1800	248	39-40	51
		4,5	310,51	KL4TR	2,00	1,50	2965	1410	4500	1800	248	39-40	51
		5,2	269,09	KL4TR	2,00	1,75	2570	1410	4220	1688	248	39-40	51
		5,7	247,86	KL4TR	2,00	1,90	2367	1410	4220	1688	248	39-40	51
		7,0	201,44	KL4TR	2,00	2,35	1924	1410	4220	1688	248	39-40	51
		8,4	167,69	KL4TR	2,00	2,80	1601	1410	4220	1688	248	39-40	51
		9,9	142,03	KL4TR	2,00	3,30	1356	1410	4220	1688	248	39-40	51
		11,6	121,87	KL4TR	2,00	3,85	1164	1410	4220	1688	248	39-40	51
		7,8	117,49	KL4	2,00 /6	2,75	1747	920	4220	1688	243	37-38	51
		9,9	92,51	KL4	2,00 /6	3,45	1375	920	4220	1688	243	37-38	51
		4,3	325,03	KL3TR	2,00	1,05	3104	1410	3200	1280	177	39-40	51
		5,1	278,90	KL3TR	2,00	1,20	2663	1410	3000	1200	177	39-40	51
		5,8	241,69	KL3TR	2,00	1,40	2308	1410	3000	1200	177	39-40	51
		6,6	215,18	KL3TR	2,00	1,55	2055	1410	3000	1200	177	39-40	51
		8,1	174,88	KL3TR	2,00	1,90	1670	1410	3000	1200	177	39-40	51

Potencia Entrada		Velocidad Salida aprox.	Relación	MODELO		Factor de Seguridad	Momento Util	Velocidad Entrada aprox.	Carga Radial adm.	Carga Axial adm.	Peso aprox.	Medidas	Repuestos
kW	HP	(RPM)	(i)			(fz)	(Nm)	(RPM)	(kg)	(kg)	(kg)	Página	Página
1,50 kW	2,00 HP	9,7	145,57	KL3TR	2,00	2,30	1390	1410	3000	1200	177	39-40	51
		11,4	123,30	KL3TR	2,00	2,70	1177	1410	3000	1200	177	39-40	51
		13,3	105,80	KL3TR	2,00	3,15	1010	1410	3000	1200	177	39-40	51
		15,4	91,69	KL3TR	2,00	3,65	876	1410	3000	1200	177	39-40	51
		8,7	105,53	KL3	2,00 /6	2,10	1569	920	3000	1200	172	37-38	51
		11,1	82,61	KL3	2,00 /6	2,70	1228	920	3000	1200	172	37-38	51
		13,7	66,92	KL3	2,00 /6	3,35	995	920	3000	1200	172	37-38	51
		13,0	105,53	KL3	2,00	3,20	1024	1410	3000	1200	162	37-38	51
		8,1	173,40	KL2TR	2,00	0,95	1656	1410	1960	784	117	39-40	51
		9,8	144,34	KL2TR	2,00	1,15	1378	1410	1960	784	117	39-40	51
		11,5	122,25	KL2TR	2,00	1,35	1167	1410	1960	784	117	39-40	51
		13,4	104,90	KL2TR	2,00	1,60	1002	1410	1960	784	117	39-40	51
		15,5	90,91	KL2TR	2,00	1,85	868	1410	1960	784	117	39-40	51
		8,5	108,81	KL2	2,00 /6	1,05	1618	920	1960	784	112	37-38	51
		10,9	84,62	KL2	2,00 /6	1,35	1258	920	1960	784	112	37-38	51
		13,5	68,07	KL2	2,00 /6	1,65	1012	920	1960	784	112	37-38	51
		13,0	108,81	KL2	2,00	1,55	1056	1410	1960	784	102	37-38	51
		17,0	84,62	KL2	2,00	2,00	821	1410	1960	784	102	37-38	51
		21,0	68,07	KL2	2,00	2,50	660	1410	1960	784	102	37-38	51
		25,0	56,03	KL2	2,00	3,05	544	1410	1880	752	102	37-38	51
		27,0	53,11	KL2	2,00	3,20	515	1410	1880	752	102	37-38	51
		29,0	48,22	KL2	2,00	3,55	468	1410	1880	752	102	37-38	51
		30,0	46,88	KL2	2,00	3,65	455	1410	1880	752	102	37-38	51
		33,0	42,72	KL2	2,00	4,00	414	1410	1880	752	102	37-38	51

Potencia Entrada		Velocidad Salida aprox.	Relación	MODELO		Factor de Seguridad	Momento Util	Velocidad Entrada aprox.	Carga Radial adm.	Carga Axial adm.	Peso aprox.	Medidas	Repuestos
kW	HP	(RPM)	(i)			(fz)	(Nm)	(RPM)	(kg)	(kg)	(kg)	Página	Página

2,20 kW
3,00 HP

2,3	622,34	KL5HR	3,00	1,55	8914	1410	9500	3800	568	39-40	51
2,9	486,45	KL5HR	3,00	1,95	6968	1410	9500	3800	568	39-40	51
3,6	393,47	KL5HR	3,00	2,40	5636	1410	9500	3800	568	39-40	51
4,4	320,30	KL5HR	3,00	2,95	4588	1410	9500	3800	568	39-40	51
5,1	274,46	KL5HR	3,00	3,45	3931	1410	9500	3800	568	39-40	51
2,6	544,56	KL45HR	3,00	1,00	7800	1410	7200	2880	373	39-40	51
3,2	440,48	KL45HR	3,00	1,25	6309	1410	7200	2880	373	39-40	51
3,9	362,28	KL45HR	3,00	1,50	5189	1410	7200	2880	373	39-40	51
5,0	283,17	KL45HR	3,00	1,90	4056	1410	7070	2828	373	39-40	51
6,2	229,05	KL45HR	3,00	2,40	3281	1410	7070	2828	373	39-40	51
7,4	189,69	KL45HR	3,00	2,85	2717	1410	7070	2828	373	39-40	51
8,8	159,77	KL45HR	3,00	3,40	2289	1410	7070	2828	373	39-40	51
10,3	136,26	KL45HR	3,00	4,00	1952	1410	7070	2828	373	39-40	51
8,2	114,64	KL45	3,00 /6	3,25	2503	940	7070	2828	367	37-38	51
4,5	310,51	KL4TR	3,00	1,00	4448	1410	4500	1800	254	39-40	51
5,2	269,09	KL4TR	3,00	1,15	3854	1410	4220	1688	254	39-40	51
5,7	247,86	KL4TR	3,00	1,25	3550	1410	4220	1688	254	39-40	51
7,0	201,44	KL4TR	3,00	1,55	2885	1410	4220	1688	254	39-40	51
8,4	167,69	KL4TR	3,00	1,85	2402	1410	4220	1688	254	39-40	51
9,9	142,03	KL4TR	3,00	2,20	2034	1410	4220	1688	254	39-40	51
11,6	121,87	KL4TR	3,00	2,60	1746	1410	4220	1688	254	39-40	51
13,4	105,61	KL4TR	3,00	2,95	1513	1410	4220	1688	254	39-40	51
8,0	117,49	KL4	3,00 /6	1,80	2565	940	4220	1688	253	37-38	51
10,2	92,51	KL4	3,00 /6	2,30	2019	940	4220	1688	253	37-38	51

Potencia Entrada		Velocidad Salida aprox.	Relación	MODELO		Factor de Seguridad	Momento Util	Velocidad Entrada aprox.	Carga Radial adm.	Carga Axial adm.	Peso aprox.	Medidas	Repuestos
kW	HP	(RPM)	(i)			(fz)	(Nm)	(RPM)	(kg)	(kg)	(kg)	Página	Página

2,20 kW
3,00 HP

12,0	117,49	KL4	3,00	2,75	1710	1410	4220	1688	239	37-38	51
15,2	92,51	KL4	3,00	3,45	1346	1410	4220	1688	239	37-38	51
6,6	215,18	KL3TR	3,00	1,05	3082	1410	3000	1200	183	39-40	51
8,1	174,88	KL3TR	3,00	1,30	2505	1410	3000	1200	183	39-40	51
9,7	145,57	KL3TR	3,00	1,55	2085	1410	3000	1200	183	39-40	51
11,4	123,30	KL3TR	3,00	1,80	1766	1410	3000	1200	183	39-40	51
13,3	105,80	KL3TR	3,00	2,10	1515	1410	3000	1200	183	39-40	51
15,4	91,69	KL3TR	3,00	2,45	1313	1410	3000	1200	183	39-40	51
8,9	105,53	KL3	3,00 /6	1,40	2304	940	3000	1200	182	37-38	51
11,4	82,61	KL3	3,00 /6	1,80	1803	940	3000	1200	182	37-38	51
14,0	66,92	KL3	3,00 /6	2,25	1461	940	3000	1200	182	37-38	51
13,0	105,53	KL3	3,00	2,10	1536	1410	3000	1200	168	37-38	51
17,0	82,61	KL3	3,00	2,70	1202	1410	3000	1200	168	37-38	51
21,0	66,92	KL3	3,00	3,35	974	1410	2860	1144	168	37-38	51
13,4	104,90	KL2TR	3,00	1,05	1503	1410	1960	784	123	39-40	51
15,5	90,91	KL2TR	3,00	1,25	1302	1410	1960	784	123	39-40	51
13,8	68,07	KL2	3,00 /6	1,10	1486	940	1960	784	122	37-38	51
13,0	108,81	KL2	3,00	1,05	1583	1410	1960	784	108	37-38	51
17,0	84,62	KL2	3,00	1,35	1231	1410	1960	784	108	37-38	51
21,0	68,07	KL2	3,00	1,65	991	1410	1960	784	108	37-38	51
25,0	56,03	KL2	3,00	2,05	815	1410	1880	752	108	37-38	51
27,0	53,11	KL2	3,00	2,15	773	1410	1880	752	108	37-38	51

Potencia Entrada		Velocidad Salida aprox.	Relación	MODELO		Factor de Seguridad	Momento Util	Velocidad Entrada aprox.	Carga Radial adm.	Carga Axial adm.	Peso aprox.	Medidas	Repuestos
kW	HP	(RPM)	(i)			(fz)	(Nm)	(RPM)	(kg)	(kg)	(kg)	Página	Página
		29,0	48,22	KL2	3,00	2,35	702	1410	1880	752	108	37-38	51
		30,0	46,88	KL2	3,00	2,45	682	1410	1880	752	108	37-38	51
		33,0	42,72	KL2	3,00	2,65	622	1410	1880	752	108	37-38	51
		36,0	39,69	KL2	3,00	2,85	578	1410	1880	752	108	37-38	51
		38,0	37,50	KL2	3,00	3,05	546	1410	1680	672	108	37-38	51
		40,0	35,16	KL2	3,00	3,25	512	1410	1680	672	108	37-38	51
		42,0	33,90	KL2	3,00	3,35	493	1410	1680	672	108	37-38	51
		47,0	30,16	KL2	3,00	3,75	439	1410	1680	672	108	37-38	51

2,20 kW
3,00 HP

Potencia Entrada		Velocidad Salida aprox.	Relación	MODELO		Factor de Seguridad	Momento Util	Velocidad Entrada aprox.	Carga Radial adm.	Carga Axial adm.	Peso aprox.	Medidas	Repuestos
kW	HP	(RPM)	(i)			(fz)	(Nm)	(RPM)	(kg)	(kg)	(kg)	Página	Página
		2,3	622,34	KL5HR	4,00	1,15	11802	1420	9500	3800	575	39-40	51
		2,9	486,45	KL5HR	4,00	1,50	9225	1420	9500	3800	575	39-40	51
		3,6	393,47	KL5HR	4,00	1,85	7462	1420	9500	3800	575	39-40	51
		4,4	320,30	KL5HR	4,00	2,25	6074	1420	9500	3800	575	39-40	51
		5,2	274,46	KL5HR	4,00	2,60	5205	1420	9500	3800	575	39-40	51
		6,1	234,08	KL5HR	4,00	3,05	4439	1420	9500	3800	575	39-40	51
		3,2	440,48	KL45HR	4,00	0,95	8353	1420	7200	2880	380	39-40	51
		3,9	362,28	KL45HR	4,00	1,15	6870	1420	7200	2880	380	39-40	51
		5,0	283,17	KL45HR	4,00	1,45	5370	1420	7070	2828	380	39-40	51
		6,2	229,05	KL45HR	4,00	1,80	4344	1420	7070	2828	380	39-40	51
		7,5	189,69	KL45HR	4,00	2,15	3597	1420	7070	2828	380	39-40	51
		8,9	159,77	KL45HR	4,00	2,55	3030	1420	7070	2828	380	39-40	51
		10,4	136,26	KL45HR	4,00	3,00	2584	1420	7070	2828	380	39-40	51
		12,1	117,31	KL45HR	4,00	3,50	2225	1420	7070	2828	380	39-40	51
		14,0	101,70	KL45HR	4,00	4,00	1929	1420	7070	2828	380	39-40	51
		8,3	114,64	KL45	4,00 /6	2,40	3284	955	7070	2828	385	37-38	51
		10,7	89,42	KL45	4,00 /6	3,10	2562	955	7070	2828	385	37-38	51
		13,2	72,17	KL45	4,00 /6	3,85	2067	955	7070	2828	385	37-38	51
		12,4	114,64	KL45	4,00	3,65	2209	1420	7070	2828	360	37-38	51
		5,7	247,86	KL4TR	4,00	0,95	4700	1420	4220	1688	261	39-40	51
		7,0	201,44	KL4TR	4,00	1,15	3820	1420	4220	1688	261	39-40	51
		8,5	167,69	KL4TR	4,00	1,40	3180	1420	4220	1688	261	39-40	51
		10,0	142,03	KL4TR	4,00	1,65	2693	1420	4220	1688	261	39-40	51
		11,7	121,87	KL4TR	4,00	1,95	2311	1420	4220	1688	261	39-40	51
		13,4	105,61	KL4TR	4,00	2,25	2003	1420	4220	1688	261	39-40	51

3,00 kW
4,00 HP

Potencia Entrada		Velocidad Salida aprox.	Relación	MODELO	Factor de Seguridad	Momento Util	Velocidad Entrada aprox.	Carga Radial adm.	Carga Axial adm.	Peso aprox.	Medidas	Repuestos	
kW	HP	(RPM)	(i)		(fz)	(Nm)	(RPM)	(kg)	(kg)	(kg)	Página	Página	
3,00 kW	4,00 HP	8,1	117,49	KL4	4,00 /6	1,35	3366	955	4220	1688	271	37-38	51
		10,3	92,51	KL4	4,00 /6	1,75	2650	955	4220	1688	271	37-38	51
		12,1	117,49	KL4	4,00	2,05	2264	1420	4220	1688	246	37-38	51
		15,4	92,51	KL4	4,00	2,60	1782	1420	4220	1688	246	37-38	51
		18,8	75,42	KL4	4,00	3,20	1453	1420	4220	1688	246	37-38	51
		22,5	62,98	KL4	4,00	3,80	1214	1420	4020	1608	246	37-38	51
		8,1	174,88	KL3TR	4,00	0,95	3316	1420	3000	1200	190	39-40	51
		9,8	145,57	KL3TR	4,00	1,15	2761	1420	3000	1200	190	39-40	51
		11,5	123,30	KL3TR	4,00	1,35	2338	1420	3000	1200	190	39-40	51
		13,4	105,80	KL3TR	4,00	1,60	2006	1420	3000	1200	190	39-40	51
		15,5	91,69	KL3TR	4,00	1,85	1739	1420	3000	1200	190	39-40	51
		9,0	105,53	KL3	4,00 /6	1,05	3023	955	3000	1200	200	37-38	51
		11,6	82,61	KL3	4,00 /6	1,35	2366	955	3000	1200	200	37-38	51
		14,3	66,92	KL3	4,00 /6	1,65	1917	955	3000	1200	200	37-38	51
		13,0	105,53	KL3	4,00	1,60	2033	1420	3000	1200	175	37-38	51
		17,0	82,61	KL3	4,00	2,05	1592	1420	3000	1200	175	37-38	51
		21,0	66,92	KL3	4,00	2,50	1289	1420	2860	1144	175	37-38	51
		26,0	55,51	KL3	4,00	3,00	1070	1420	2860	1144	175	37-38	51
		30,0	46,84	KL3	4,00	3,60	903	1420	2860	1144	175	37-38	51
		17,0	84,62	KL2	4,00	1,00	1630	1420	1960	784	115	37-38	51
21,0	68,07	KL2	4,00	1,25	1311	1420	1960	784	115	37-38	51		
25,0	56,03	KL2	4,00	1,50	1080	1420	1880	752	115	37-38	51		
27,0	53,11	KL2	4,00	1,60	1023	1420	1880	752	115	37-38	51		
29,0	48,22	KL2	4,00	1,75	929	1420	1880	752	115	37-38	51		

Potencia Entrada		Velocidad Salida aprox.	Relación	MODELO	Factor de Seguridad	Momento Util	Velocidad Entrada aprox.	Carga Radial adm.	Carga Axial adm.	Peso aprox.	Medidas	Repuestos	
kW	HP	(RPM)	(i)		(fz)	(Nm)	(RPM)	(kg)	(kg)	(kg)	Página	Página	
3,00 kW	4,00 HP	30,0	46,88	KL2	4,00	1,80	903	1420	1880	752	115	37-38	51
		33,0	42,72	KL2	4,00	2,00	823	1420	1880	752	115	37-38	51
		36,0	39,69	KL2	4,00	2,15	765	1420	1880	752	115	37-38	51
		38,0	37,50	KL2	4,00	2,30	722	1420	1680	672	115	37-38	51
		40,0	35,16	KL2	4,00	2,45	677	1420	1680	672	115	37-38	51
		42,0	33,90	KL2	4,00	2,50	653	1420	1680	672	115	37-38	51
		47,0	30,16	KL2	4,00	2,85	581	1420	1680	672	115	37-38	51
		57,0	24,83	KL2	4,00	3,45	478	1420	1680	672	115	37-38	51

Potencia Entrada		Velocidad Salida aprox.	Relación	MODELO		Factor de Seguridad	Momento Util	Velocidad Entrada aprox.	Carga Radial adm.	Carga Axial adm.	Peso aprox.	Medidas	Repuestos
kW	HP	(RPM)	(i)			(fz)	(Nm)	(RPM)	(kg)	(kg)	(kg)	Página	Página
4,00 kW	5,50 HP	3,0	486,45	KL5HR	5,50	1,10	12508	1440	9500	3800	578	39-40	51
		3,7	393,47	KL5HR	5,50	1,35	10118	1440	9500	3800	578	39-40	51
		4,5	320,30	KL5HR	5,50	1,65	8236	1440	9500	3800	578	39-40	51
		5,2	274,46	KL5HR	5,50	1,95	7057	1440	9500	3800	578	39-40	51
		6,2	234,08	KL5HR	5,50	2,25	6019	1440	9500	3800	578	39-40	51
		7,7	186,30	KL5HR	5,50	2,85	4790	1440	9500	3800	578	39-40	51
		9,1	158,89	KL5HR	5,50	3,35	4086	1440	9500	3800	578	39-40	51
		9,4	102,41	KL5	5,50 /6	3,70	4013	960	9500	3800	584	37-38	51
		5,1	283,17	KL45HR	5,50	1,05	7281	1440	7070	2828	383	39-40	51
		6,3	229,05	KL45HR	5,50	1,30	5890	1440	7070	2828	383	39-40	51
		7,6	189,69	KL45HR	5,50	1,55	4877	1440	7070	2828	383	39-40	51
		9,0	159,77	KL45HR	5,50	1,85	4108	1440	7070	2828	383	39-40	51
		10,6	136,26	KL45HR	5,50	2,20	3504	1440	7070	2828	383	39-40	51
		12,3	117,31	KL45HR	5,50	2,55	3016	1440	7070	2828	383	39-40	51
		14,2	101,70	KL45HR	5,50	2,90	2615	1440	7070	2828	383	39-40	51
		8,4	114,64	KL45	5,50 /6	1,75	4492	960	7070	2828	389	37-38	51
		10,7	89,42	KL45	5,50 /6	2,25	3504	960	7070	2828	389	37-38	51
		13,3	72,17	KL45	5,50 /6	2,80	2828	960	7070	2828	389	37-38	51
		14,2	67,80	KL45	5,50 /6	3,00	2657	960	7070	2828	389	37-38	51
		12,6	114,64	KL45	5,50	2,65	2995	1440	7070	2828	363	37-38	51
		16,1	89,42	KL45	5,50	3,40	2336	1440	7070	2828	363	37-38	51
		8,5	168,80	KL4HR	5,50	1,00	4340	1440	4220	1688	269	39-40	51
		10,0	143,96	KL4HR	5,50	1,20	3702	1440	4220	1688	269	39-40	51
		11,6	123,94	KL4HR	5,50	1,40	3187	1440	4220	1688	269	39-40	51
		13,4	107,44	KL4HR	5,50	1,60	2763	1440	4220	1688	269	39-40	51

Potencia Entrada		Velocidad Salida aprox.	Relación	MODELO		Factor de Seguridad	Momento Util	Velocidad Entrada aprox.	Carga Radial adm.	Carga Axial adm.	Peso aprox.	Medidas	Repuestos
kW	HP	(RPM)	(i)			(fz)	(Nm)	(RPM)	(kg)	(kg)	(kg)	Página	Página
4,00 kW	5,50 HP	8,2	117,49	KL4	5,50 /6	1,00	4604	960	4220	1688	275	37-38	51
		10,4	92,51	KL4	5,50 /6	1,25	3625	960	4220	1688	275	37-38	51
		12,3	117,49	KL4	5,50	1,50	3069	1440	4220	1688	249	37-38	51
		15,6	92,51	KL4	5,50	1,90	2417	1440	4220	1688	249	37-38	51
		19,1	75,42	KL4	5,50	2,30	1970	1440	4220	1688	249	37-38	51
		22,9	62,98	KL4	5,50	2,75	1645	1440	4020	1608	249	37-38	51
		26,9	53,54	KL4	5,50	3,25	1399	1440	4020	1608	249	37-38	51
		31,2	46,11	KL4	5,50	3,80	1205	1440	4020	1608	249	37-38	51
		11,7	123,30	KL3TR	5,50	1,00	3171	1440	3000	1200	193	39-40	51
		13,6	105,80	KL3TR	5,50	1,15	2721	1440	3000	1200	193	39-40	51
		15,7	91,69	KL3TR	5,50	1,35	2358	1440	3000	1200	193	39-40	51
		11,6	82,61	KL3	5,50 /6	1,00	3237	960	3000	1200	204	37-38	51
		14,3	66,92	KL3	5,50 /6	1,20	2622	960	3000	1200	204	37-38	51
		14,0	105,53	KL3	5,50	1,15	2757	1440	3000	1200	178	37-38	51
		17,0	82,61	KL3	5,50	1,50	2158	1440	3000	1200	178	37-38	51
		22,0	66,92	KL3	5,50	1,80	1748	1440	2860	1144	178	37-38	51
		26,0	55,51	KL3	5,50	2,20	1450	1440	2860	1144	178	37-38	51
		31,0	46,84	KL3	5,50	2,60	1224	1440	2860	1144	178	37-38	51
		36,0	40,03	KL3	5,50	3,05	1046	1440	2860	1144	178	37-38	51
		39,0	36,60	KL3	5,50	3,35	956	1440	2860	1144	178	37-38	51
		42,0	34,54	KL3	5,50	3,55	902	1440	2560	1024	178	37-38	51
		26,0	56,03	KL2	5,50	1,10	1464	1440	1880	752	118	37-38	51
		27,0	53,11	KL2	5,50	1,15	1387	1440	1880	752	118	37-38	51
		30,0	48,22	KL2	5,50	1,30	1260	1440	1880	752	118	37-38	51
		31,0	46,88	KL2	5,50	1,35	1225	1440	1880	752	118	37-38	51

Potencia Entrada		Velocidad Salida aprox.	Relación	MODELO		Factor de Seguridad	Momento Útil	Velocidad Entrada aprox.	Carga Radial adm.	Carga Axial adm.	Peso aprox.	Medidas	Repuestos
kW	HP	(RPM)	(i)			(fz)	(Nm)	(RPM)	(kg)	(kg)	(kg)	Página	Página
4,00 kW	5,50 HP	34,0	42,72	KL2	5,50	1,45	1116	1440	1880	752	118	37-38	51
		36,0	39,69	KL2	5,50	1,55	1037	1440	1880	752	118	37-38	51
		38,0	37,50	KL2	5,50	1,65	980	1440	1680	672	118	37-38	51
		41,0	35,16	KL2	5,50	1,75	919	1440	1680	672	118	37-38	51
		42,0	33,90	KL2	5,50	1,85	886	1440	1680	672	118	37-38	51
		48,0	30,16	KL2	5,50	2,05	788	1440	1680	672	118	37-38	51
		58,0	24,83	KL2	5,50	2,50	649	1440	1680	672	118	37-38	51
		69,0	20,77	KL2	5,50	2,95	543	1440	1460	584	118	37-38	51
		76,0	18,93	KL2	5,50	3,10	495	1440	1460	584	118	37-38	51
		82,0	17,59	KL2	5,50	3,35	459	1440	1150	460	118	37-38	51
		92,0	15,58	KL2	5,50	3,75	407	1440	1150	460	118	37-38	51
		96,0	15,02	KL2	5,50	3,80	392	1440	1150	460	118	37-38	51

Potencia Entrada		Velocidad Salida aprox.	Relación	MODELO		Factor de Seguridad	Momento Útil	Velocidad Entrada aprox.	Carga Radial adm.	Carga Axial adm.	Peso aprox.	Medidas	Repuestos
kW	HP	(RPM)	(i)			(fz)	(Nm)	(RPM)	(kg)	(kg)	(kg)	Página	Página
5,50 kW	7,50 HP	3,7	393,47	KL5HR	7,50	1,00	13561	1465	9500	3800	592	39-40	51
		4,6	320,30	KL5HR	7,50	1,25	11039	1465	9500	3800	592	39-40	51
		5,3	274,46	KL5HR	7,50	1,45	9459	1465	9500	3800	592	39-40	51
		6,3	234,08	KL5HR	7,50	1,70	8068	1465	9500	3800	592	39-40	51
		7,9	186,30	KL5HR	7,50	2,10	6421	1465	9500	3800	592	39-40	51
		9,2	158,89	KL5HR	7,50	2,50	5476	1465	9500	3800	592	39-40	51
		10,7	136,79	KL5HR	7,50	2,90	4714	1465	9500	3800	592	39-40	51
		12,4	118,58	KL5HR	7,50	3,35	4087	1465	9500	3800	592	39-40	51
		9,4	102,41	KL5	7,50 /6	2,70	5472	960	9500	3800	597	37-38	51
		11,5	83,37	KL5	7,50 /6	3,25	4455	960	9500	3800	597	37-38	51
		13,8	69,52	KL5	7,50 /6	3,85	3715	960	9500	3800	597	37-38	51
		6,4	229,05	KL45HR	7,50	0,95	7894	1465	7070	2828	397	39-40	51
		7,7	189,69	KL45HR	7,50	1,15	6538	1465	7070	2828	397	39-40	51
		9,2	159,77	KL45HR	7,50	1,35	5507	1465	7070	2828	397	39-40	51
		10,8	136,26	KL45HR	7,50	1,60	4696	1465	7070	2828	397	39-40	51
		12,5	117,31	KL45HR	7,50	1,85	4043	1465	7070	2828	397	39-40	51
		14,4	101,70	KL45HR	7,50	2,15	3505	1465	7070	2828	397	39-40	51
		8,4	114,64	KL45	7,50 /6	1,30	6126	960	7070	2828	402	37-38	51
		10,7	89,42	KL45	7,50 /6	1,65	4778	960	7070	2828	402	37-38	51
		13,3	72,17	KL45	7,50 /6	2,05	3856	960	7070	2828	402	37-38	51
		14,2	67,80	KL45	7,50 /6	2,20	3623	960	7070	2828	402	37-38	51
		12,8	114,64	KL45	7,50	1,95	4014	1465	7070	2828	377	37-38	51
		16,4	89,42	KL45	7,50	2,50	3131	1465	7070	2828	377	37-38	51
		20,3	72,17	KL45	7,50	3,10	2527	1465	7070	2828	377	37-38	51
		21,6	67,80	KL45	7,50	3,25	2374	1465	5840	2336	377	37-38	51
		24,6	59,62	KL45	7,50	3,70	2087	1465	5840	2336	377	37-38	51

Potencia Entrada		Velocidad Salida aprox.	Relación	MODELO		Factor de Seguridad	Momento Util	Velocidad Entrada aprox.	Carga Radial adm.	Carga Axial adm.	Peso aprox.	Medidas	Repuestos		
kW	HP	(RPM)	(i)			(fz)	(Nm)	(RPM)	(kg)	(kg)	(kg)	Página	Página		
5,50	kW	7,50	HP												
				11,8	123,94	KL4HR	7,50	1,00	4272	1465	4220	1688	283	39-40	51
				13,6	107,44	KL4HR	7,50	1,15	3703	1465	4220	1688	283	39-40	51
				12,5	117,49	KL4	7,50	1,10	4114	1465	4220	1688	263	37-38	51
				15,8	92,51	KL4	7,50	1,40	3239	1465	4220	1688	263	37-38	51
				19,4	75,42	KL4	7,50	1,70	2641	1465	4220	1688	263	37-38	51
				23,3	62,98	KL4	7,50	2,05	2205	1465	4020	1608	263	37-38	51
				27,4	53,54	KL4	7,50	2,40	1875	1465	4020	1608	263	37-38	51
				31,8	46,11	KL4	7,50	2,80	1615	1465	4020	1608	263	37-38	51
				34,0	42,78	KL4	7,50	3,00	1498	1465	4020	1608	263	37-38	51
				37,0	40,13	KL4	7,50	3,20	1405	1465	4020	1608	263	37-38	51
				42,0	35,20	KL4	7,50	3,65	1232	1465	3600	1440	263	37-38	51
				44,0	33,42	KL4	7,50	3,85	1170	1465	3600	1440	263	37-38	51
				18,0	82,61	KL3	7,50	1,10	2892	1465	3000	1200	192	37-38	51
				22,0	66,92	KL3	7,50	1,35	2343	1465	2860	1144	192	37-38	51
				26,0	55,51	KL3	7,50	1,60	1944	1465	2860	1144	192	37-38	51
				31,0	46,84	KL3	7,50	1,90	1640	1465	2860	1144	192	37-38	51
				37,0	40,03	KL3	7,50	2,25	1402	1465	2860	1144	192	37-38	51
				40,0	36,60	KL3	7,50	2,45	1282	1465	2860	1144	192	37-38	51
				42,0	34,54	KL3	7,50	2,60	1209	1465	2560	1024	192	37-38	51
				49,0	30,02	KL3	7,50	3,00	1051	1465	2560	1024	192	37-38	51
				56,0	26,23	KL3	7,50	3,40	918	1465	2560	1024	192	37-38	51
				60,0	24,60	KL3	7,50	3,65	861	1465	2560	1024	192	37-38	51
				64,0	23,00	KL3	7,50	3,90	805	1465	2220	888	192	37-38	51
				30,0	48,22	KL2	7,50	0,95	1688	1465	1880	752	132	37-38	51
				31,0	46,88	KL2	7,50	0,95	1642	1465	1880	752	132	37-38	51
				34,0	42,72	KL2	7,50	1,05	1496	1465	1880	752	132	37-38	51

Potencia Entrada		Velocidad Salida aprox.	Relación	MODELO		Factor de Seguridad	Momento Util	Velocidad Entrada aprox.	Carga Radial adm.	Carga Axial adm.	Peso aprox.	Medidas	Repuestos		
kW	HP	(RPM)	(i)			(fz)	(Nm)	(RPM)	(kg)	(kg)	(kg)	Página	Página		
5,50	kW	7,50	HP												
				37,0	39,69	KL2	7,50	1,15	1390	1465	1880	752	132	37-38	51
				39,0	37,50	KL2	7,50	1,20	1313	1465	1680	672	132	37-38	51
				42,0	35,16	KL2	7,50	1,30	1231	1465	1680	672	132	37-38	51
				43,0	33,90	KL2	7,50	1,35	1187	1465	1680	672	132	37-38	51
				49,0	30,16	KL2	7,50	1,50	1056	1465	1680	672	132	37-38	51
				59,0	24,83	KL2	7,50	1,85	869	1465	1680	672	132	37-38	51
				71,0	20,77	KL2	7,50	2,15	727	1465	1460	584	132	37-38	51
				77,0	18,93	KL2	7,50	2,25	663	1465	1460	584	132	37-38	51
				83,0	17,59	KL2	7,50	2,45	616	1465	1150	460	132	37-38	51
				94,0	15,58	KL2	7,50	2,75	546	1465	1150	460	132	37-38	51
				98,0	15,02	KL2	7,50	2,75	526	1465	1150	460	132	37-38	51
				112,0	13,04	KL2	7,50	3,20	457	1465	1150	460	132	37-38	51
				133,0	11,04	KL2	7,50	3,65	387	1465	1050	420	132	37-38	51

Potencia Entrada		Velocidad Salida aprox.	Relación	MODELO		Factor de Seguridad	Momento Util	Velocidad Entrada aprox.	Carga Radial adm.	Carga Axial adm.	Peso aprox.	Medidas	Repuestos
kW	HP	(RPM)	(i)			(fz)	(Nm)	(RPM)	(kg)	(kg)	(kg)	Página	Página
7,50 kW	10,00 HP	5,3	274,46	KL5HR	10,00	1,10	12656	1460	9500	3800	610	39-40	51
		6,2	234,08	KL5HR	10,00	1,25	10794	1460	9500	3800	610	39-40	51
		7,8	186,30	KL5HR	10,00	1,60	8591	1460	9500	3800	610	39-40	51
		9,2	158,89	KL5HR	10,00	1,85	7327	1460	9500	3800	610	39-40	51
		10,7	136,79	KL5HR	10,00	2,15	6307	1460	9500	3800	610	39-40	51
		12,3	118,58	KL5HR	10,00	2,50	5468	1460	9500	3800	610	39-40	51
		14,5	100,63	KL5HR	10,00	2,95	4640	1460	9500	3800	610	39-40	51
		16,9	86,52	KL5HR	10,00	3,40	3989	1460	9500	3800	610	39-40	51
		9,4	102,41	KL5	10,00 /6	2,05	7259	965	9500	3800	628	37-38	51
		11,6	83,37	KL5	10,00 /6	2,45	5909	965	9500	3800	628	37-38	51
		13,9	69,52	KL5	10,00 /6	2,90	4927	965	9500	3800	628	37-38	51
		16,4	58,99	KL5	10,00 /6	3,40	4181	965	9500	3800	628	37-38	51
		19,0	50,72	KL5	10,00 /6	4,00	3595	965	9500	3800	628	37-38	51
		14,0	102,41	KL5	10,00	3,05	4798	1460	9500	3800	590	37-38	51
		18,0	83,37	KL5	10,00	3,65	3905	1460	9500	3800	590	37-38	51
		9,1	159,77	KL45HR	10,00	1,00	7367	1460	7070	2828	415	39-40	51
		10,7	136,26	KL45HR	10,00	1,20	6283	1460	7070	2828	415	39-40	51
		12,4	117,31	KL45HR	10,00	1,40	5409	1460	7070	2828	415	39-40	51
		14,4	101,70	KL45HR	10,00	1,60	4689	1460	7070	2828	415	39-40	51
		8,4	114,64	KL45	10,00 /6	0,95	8126	965	7070	2828	433	37-38	51
		10,8	89,42	KL45	10,00 /6	1,25	6338	965	7070	2828	433	37-38	51
		13,4	72,17	KL45	10,00 /6	1,55	5115	965	7070	2828	433	37-38	51
		14,2	67,80	KL45	10,00 /6	1,65	4805	965	7070	2828	433	37-38	51
		12,7	114,64	KL45	10,00	1,45	5371	1460	7070	2828	395	37-38	51
		16,3	89,42	KL45	10,00	1,85	4189	1460	7070	2828	395	37-38	51

Potencia Entrada		Velocidad Salida aprox.	Relación	MODELO		Factor de Seguridad	Momento Util	Velocidad Entrada aprox.	Carga Radial adm.	Carga Axial adm.	Peso aprox.	Medidas	Repuestos
kW	HP	(RPM)	(i)			(fz)	(Nm)	(RPM)	(kg)	(kg)	(kg)	Página	Página
7,50 kW	10,00 HP	20,2	72,17	KL45	10,00	2,30	3381	1460	7070	2828	395	37-38	51
		21,5	67,80	KL45	10,00	2,45	3176	1460	5840	2336	395	37-38	51
		24,5	59,62	KL45	10,00	2,80	2793	1460	5840	2336	395	37-38	51
		29,2	50,08	KL45	10,00	3,35	2346	1460	5840	2336	395	37-38	51
		34,3	42,58	KL45	10,00	3,90	1995	1460	5840	2336	395	37-38	51
		15,8	92,51	KL4	10,00	1,05	4334	1460	4220	1688	281	37-38	51
		19,4	75,42	KL4	10,00	1,25	3533	1460	4220	1688	281	37-38	51
		23,2	62,98	KL4	10,00	1,55	2951	1460	4020	1608	281	37-38	51
		27,3	53,54	KL4	10,00	1,80	2508	1460	4020	1608	281	37-38	51
		31,7	46,11	KL4	10,00	2,10	2160	1460	4020	1608	281	37-38	51
		34,0	42,78	KL4	10,00	2,25	2004	1460	4020	1608	281	37-38	51
		36,0	40,13	KL4	10,00	2,40	1880	1460	4020	1608	281	37-38	51
		41,0	35,20	KL4	10,00	2,75	1649	1460	3600	1440	281	37-38	51
		44,0	33,42	KL4	10,00	2,90	1566	1460	3600	1440	281	37-38	51
		47,0	31,07	KL4	10,00	3,10	1455	1460	3600	1440	281	37-38	51
		53,0	27,56	KL4	10,00	3,50	1291	1460	3600	1440	281	37-38	51
		22,0	66,92	KL3	10,00	1,00	3135	1460	2860	1144	210	37-38	51
		26,0	55,51	KL3	10,00	1,20	2601	1460	2860	1144	210	37-38	51
		31,0	46,84	KL3	10,00	1,45	2195	1460	2860	1144	210	37-38	51
		36,0	40,03	KL3	10,00	1,70	1875	1460	2860	1144	210	37-38	51
		40,0	36,60	KL3	10,00	1,85	1715	1460	2860	1144	210	37-38	51
		42,0	34,54	KL3	10,00	1,95	1618	1460	2560	1024	210	37-38	51
		49,0	30,02	KL3	10,00	2,25	1406	1460	2560	1024	210	37-38	51
		56,0	26,23	KL3	10,00	2,55	1229	1460	2560	1024	210	37-38	51
		59,0	24,60	KL3	10,00	2,75	1152	1460	2560	1024	210	37-38	51
		63,0	23,00	KL3	10,00	2,90	1078	1460	2220	888	210	37-38	51
		70,0	20,76	KL3	10,00	3,25	972	1460	2220	888	210	37-38	51
		82,0	17,74	KL3	10,00	3,70	831	1460	1740	696	210	37-38	51

Potencia Entrada		Velocidad Salida aprox.	Relación	MODELO		Factor de Seguridad	Momento Util	Velocidad Entrada aprox.	Carga Radial adm.	Carga Axial adm.	Peso aprox.	Medidas	Repuestos
kW	HP	(RPM)	(i)			(fz)	(Nm)	(RPM)	(kg)	(kg)	(kg)	Página	Página
7,50 kW	10,00 HP	42,0	35,16	KL2	10,00	0,95	1647	1460	1680	672	150	37-38	51
		43,0	33,90	KL2	10,00	1,00	1588	1460	1680	672	150	37-38	51
		48,0	30,16	KL2	10,00	1,15	1413	1460	1680	672	150	37-38	51
		59,0	24,83	KL2	10,00	1,40	1163	1460	1680	672	150	37-38	51
		70,0	20,77	KL2	10,00	1,60	973	1460	1460	584	150	37-38	51
		77,0	18,93	KL2	10,00	1,70	887	1460	1460	584	150	37-38	51
		83,0	17,59	KL2	10,00	1,85	824	1460	1150	460	150	37-38	51
		94,0	15,58	KL2	10,00	2,05	730	1460	1150	460	150	37-38	51
		97,0	15,02	KL2	10,00	2,10	704	1460	1150	460	150	37-38	51
		112,0	13,04	KL2	10,00	2,40	611	1460	1150	460	150	37-38	51
		132,0	11,04	KL2	10,00	2,75	517	1460	1050	420	150	37-38	51
		155,0	9,43	KL2	10,00	3,05	442	1460	1050	420	150	37-38	51

Potencia Entrada		Velocidad Salida aprox.	Relación	MODELO		Factor de Seguridad	Momento Util	Velocidad Entrada aprox.	Carga Radial adm.	Carga Axial adm.	Peso aprox.	Medidas	Repuestos
kW	HP	(RPM)	(i)			(fz)	(Nm)	(RPM)	(kg)	(kg)	(kg)	Página	Página
9,00 kW	12,50 HP	6,2	234,08	KL5HR	12,50	1,00	13492	1460	9500	3800	638	39-40	51
		7,8	186,30	KL5HR	12,50	1,25	10738	1460	9500	3800	638	39-40	51
		9,2	158,89	KL5HR	12,50	1,50	9158	1460	9500	3800	638	39-40	51
		10,7	136,79	KL5HR	12,50	1,75	7884	1460	9500	3800	638	39-40	51
		12,3	118,58	KL5HR	12,50	2,00	6835	1460	9500	3800	638	39-40	51
		14,5	100,63	KL5HR	12,50	2,35	5800	1460	9500	3800	638	39-40	51
		16,9	86,52	KL5HR	12,50	2,75	4987	1460	9500	3800	638	39-40	51
		9,4	102,41	KL5	12,50 /6	1,60	9073	965	9500	3800	638	37-38	51
		11,6	83,37	KL5	12,50 /6	1,95	7386	965	9500	3800	638	37-38	51
		13,9	69,52	KL5	12,50 /6	2,30	6159	965	9500	3800	638	37-38	51
		16,4	58,99	KL5	12,50 /6	2,75	5226	965	9500	3800	638	37-38	51
		19,0	50,72	KL5	12,50 /6	3,20	4493	965	9500	3800	638	37-38	51
		21,9	44,05	KL5	12,50 /6	3,70	3902	965	9470	3788	638	37-38	51
		14,0	102,41	KL5	12,50	2,45	5997	1460	9500	3800	618	37-38	51
		18,0	83,37	KL5	12,50	2,95	4882	1460	9500	3800	618	37-38	51
		21,0	69,52	KL5	12,50	3,50	4071	1460	9470	3788	618	37-38	51
		10,7	136,26	KL45HR	12,50	0,95	7854	1460	7070	2828	443	39-40	51
		12,4	117,31	KL45HR	12,50	1,10	6762	1460	7070	2828	443	39-40	51
		14,4	101,70	KL45HR	12,50	1,30	5862	1460	7070	2828	443	39-40	51
		10,8	89,42	KL45	12,50 /6	1,00	7923	965	7070	2828	443	37-38	51
		13,4	72,17	KL45	12,50 /6	1,25	6394	965	7070	2828	443	37-38	51
14,2	67,80	KL45	12,50 /6	1,30	6007	965	7070	2828	443	37-38	51		
12,7	114,64	KL45	12,50	1,15	6714	1460	7070	2828	423	37-38	51		
16,3	89,42	KL45	12,50	1,50	5237	1460	7070	2828	423	37-38	51		
20,2	72,17	KL45	12,50	1,85	4226	1460	7070	2828	423	37-38	51		

Potencia Entrada		Velocidad Salida aprox.	Relación	MODELO		Factor de Seguridad	Momento Util	Velocidad Entrada aprox.	Carga Radial adm.	Carga Axial adm.	Peso aprox.	Medidas	Repuestos
kW	HP	(RPM)	(i)			(fz)	(Nm)	(RPM)	(kg)	(kg)	(kg)	Página	Página
9,00 kW	12,50 HP	21,5	67,80	KL45	12,50	1,95	3970	1460	5840	2336	423	37-38	51
		24,5	59,62	KL45	12,50	2,25	3491	1460	5840	2336	423	37-38	51
		29,2	50,08	KL45	12,50	2,65	2932	1460	5840	2336	423	37-38	51
		34,3	42,58	KL45	12,50	3,15	2494	1460	5840	2336	423	37-38	51
		36,8	39,63	KL45	12,50	3,35	2320	1460	5840	2336	423	37-38	51
		40,0	36,54	KL45	12,50	3,65	2140	1460	5840	2336	423	37-38	51
		19,4	75,42	KL4	12,50	1,00	4416	1460	4220	1688	309	37-38	51
		23,2	62,98	KL4	12,50	1,20	3688	1460	4020	1608	309	37-38	51
		27,3	53,54	KL4	12,50	1,45	3135	1460	4020	1608	309	37-38	51
		31,7	46,11	KL4	12,50	1,65	2700	1460	4020	1608	309	37-38	51
		34,0	42,78	KL4	12,50	1,80	2505	1460	4020	1608	309	37-38	51
		36,0	40,13	KL4	12,50	1,90	2350	1460	4020	1608	309	37-38	51
		41,0	35,20	KL4	12,50	2,20	2061	1460	3600	1440	309	37-38	51
		44,0	33,42	KL4	12,50	2,30	1957	1460	3600	1440	309	37-38	51
		47,0	31,07	KL4	12,50	2,45	1819	1460	3600	1440	309	37-38	51
53,0	27,56	KL4	12,50	2,80	1614	1460	3600	1440	309	37-38	51		
62,0	23,72	KL4	12,50	3,25	1389	1460	3600	1440	309	37-38	51		
71,0	20,43	KL4	12,50	3,75	1197	1460	3120	1248	309	37-38	51		
26,0	55,51	KL3	12,50	0,95	3251	1460	2860	1144	238	37-38	51		
31,0	46,84	KL3	12,50	1,15	2743	1460	2860	1144	238	37-38	51		
36,0	40,03	KL3	12,50	1,35	2344	1460	2860	1144	238	37-38	51		
40,0	36,60	KL3	12,50	1,45	2144	1460	2860	1144	238	37-38	51		
42,0	34,54	KL3	12,50	1,55	2023	1460	2560	1024	238	37-38	51		
49,0	30,02	KL3	12,50	1,80	1758	1460	2560	1024	238	37-38	51		
56,0	26,23	KL3	12,50	2,05	1536	1460	2560	1024	238	37-38	51		
59,0	24,60	KL3	12,50	2,20	1441	1460	2560	1024	238	37-38	51		
63,0	23,00	KL3	12,50	2,35	1347	1460	2220	888	238	37-38	51		

Potencia Entrada		Velocidad Salida aprox.	Relación	MODELO		Factor de Seguridad	Momento Util	Velocidad Entrada aprox.	Carga Radial adm.	Carga Axial adm.	Peso aprox.	Medidas	Repuestos
kW	HP	(RPM)	(i)			(fz)	(Nm)	(RPM)	(kg)	(kg)	(kg)	Página	Página
9,00 kW	12,50 HP	70,0	20,76	KL3	12,50	2,60	1216	1460	2220	888	238	37-38	51
		82,0	17,74	KL3	12,50	2,95	1039	1460	1740	696	238	37-38	51
		95,0	15,31	KL3	12,50	3,30	896	1460	1740	696	238	37-38	51
		110,0	13,30	KL3	12,50	3,70	779	1460	1740	696	238	37-38	51
		59,0	24,83	KL2	12,50	1,10	1454	1460	1680	672	178	37-38	51
		70,0	20,77	KL2	12,50	1,30	1217	1460	1460	584	178	37-38	51
		77,0	18,93	KL2	12,50	1,35	1108	1460	1460	584	178	37-38	51
		83,0	17,59	KL2	12,50	1,45	1030	1460	1150	460	178	37-38	51
		94,0	15,58	KL2	12,50	1,65	912	1460	1150	460	178	37-38	51
		97,0	15,02	KL2	12,50	1,65	880	1460	1150	460	178	37-38	51
		112,0	13,04	KL2	12,50	1,90	763	1460	1150	460	178	37-38	51
		132,0	11,04	KL2	12,50	2,20	646	1460	1050	420	178	37-38	51
		155,0	9,43	KL2	12,50	2,45	552	1460	1050	420	178	37-38	51

Potencia Entrada		Velocidad Salida aprox.	Relación	MODELO		Factor de Seguridad	Momento Util	Velocidad Entrada aprox.	Carga Radial adm.	Carga Axial adm.	Peso aprox.	Medidas	Repuestos
kW	HP	(RPM)	(i)			(fz)	(Nm)	(RPM)	(kg)	(kg)	(kg)	Página	Página
11,00 kW	15,00 HP	7,8	186,30	KL5HR	15,00	1,05	12886	1460	9500	3800	641	39-40	51
		9,2	158,89	KL5HR	15,00	1,25	10990	1460	9500	3800	641	39-40	51
		10,7	136,79	KL5HR	15,00	1,45	9461	1460	9500	3800	641	39-40	51
		12,3	118,58	KL5HR	15,00	1,65	8202	1460	9500	3800	641	39-40	51
		14,5	100,63	KL5HR	15,00	1,95	6960	1460	9500	3800	641	39-40	51
		16,9	86,52	KL5HR	15,00	2,30	5984	1460	9500	3800	641	39-40	51
		9,4	102,41	KL5	15,00 /6	1,35	10888	965	9500	3800	652	37-38	51
		11,6	83,37	KL5	15,00 /6	1,65	8863	965	9500	3800	652	37-38	51
		13,9	69,52	KL5	15,00 /6	1,95	7391	965	9500	3800	652	37-38	51
		16,4	58,99	KL5	15,00 /6	2,30	6271	965	9500	3800	652	37-38	51
		19,0	50,72	KL5	15,00 /6	2,65	5392	965	9500	3800	652	37-38	51
		21,9	44,05	KL5	15,00 /6	3,10	4683	965	9470	3788	652	37-38	51
		25,0	38,55	KL5	15,00 /6	3,55	4099	965	9470	3788	652	37-38	51
		26,1	36,94	KL5	15,00 /6	3,70	3927	965	9470	3788	652	37-38	51
		28,4	33,95	KL5	15,00 /6	4,00	3610	965	9470	3788	652	37-38	51
		14,0	102,41	KL5	15,00	2,05	7197	1460	9500	3800	621	37-38	51
		18,0	83,37	KL5	15,00	2,45	5858	1460	9500	3800	621	37-38	51
		21,0	69,52	KL5	15,00	2,90	4885	1460	9470	3788	621	37-38	51
		25,0	58,99	KL5	15,00	3,40	4145	1460	9470	3788	621	37-38	51
		29,0	50,72	KL5	15,00	4,00	3564	1460	9470	3788	621	37-38	51
		12,4	117,31	KL45HR	15,00	0,95	8114	1460	7070	2828	446	39-40	51
		14,4	101,70	KL45HR	15,00	1,05	7034	1460	7070	2828	446	39-40	51
		13,4	72,17	KL45	15,00 /6	1,05	7672	965	7070	2828	457	37-38	51
		14,2	67,80	KL45	15,00 /6	1,10	7208	965	7070	2828	457	37-38	51

Potencia Entrada		Velocidad Salida aprox.	Relación	MODELO		Factor de Seguridad	Momento Util	Velocidad Entrada aprox.	Carga Radial adm.	Carga Axial adm.	Peso aprox.	Medidas	Repuestos
kW	HP	(RPM)	(i)			(fz)	(Nm)	(RPM)	(kg)	(kg)	(kg)	Página	Página
11,00 kW	15,00 HP	12,7	114,64	KL45	15,00	0,95	8056	1460	7070	2828	426	37-38	51
		16,3	89,42	KL45	15,00	1,25	6284	1460	7070	2828	426	37-38	51
		20,2	72,17	KL45	15,00	1,55	5071	1460	7070	2828	426	37-38	51
		21,5	67,80	KL45	15,00	1,65	4764	1460	5840	2336	426	37-38	51
		24,5	59,62	KL45	15,00	1,85	4189	1460	5840	2336	426	37-38	51
		29,2	50,08	KL45	15,00	2,20	3519	1460	5840	2336	426	37-38	51
		34,3	42,58	KL45	15,00	2,60	2992	1460	5840	2336	426	37-38	51
		36,8	39,63	KL45	15,00	2,80	2785	1460	5840	2336	426	37-38	51
		40,0	36,54	KL45	15,00	3,05	2568	1460	5840	2336	426	37-38	51
		46,3	31,56	KL45	15,00	3,50	2218	1460	4930	1972	426	37-38	51
		23,2	62,98	KL4	15,00	1,00	4426	1460	4020	1608	312	37-38	51
		27,3	53,54	KL4	15,00	1,20	3762	1460	4020	1608	312	37-38	51
		31,7	46,11	KL4	15,00	1,40	3240	1460	4020	1608	312	37-38	51
		34,0	42,78	KL4	15,00	1,50	3006	1460	4020	1608	312	37-38	51
		36,0	40,13	KL4	15,00	1,60	2820	1460	4020	1608	312	37-38	51
		41,0	35,20	KL4	15,00	1,80	2473	1460	3600	1440	312	37-38	51
		44,0	33,42	KL4	15,00	1,90	2348	1460	3600	1440	312	37-38	51
		47,0	31,07	KL4	15,00	2,05	2183	1460	3600	1440	312	37-38	51
		53,0	27,56	KL4	15,00	2,30	1936	1460	3600	1440	312	37-38	51
		62,0	23,72	KL4	15,00	2,70	1667	1460	3600	1440	312	37-38	51
		71,0	20,43	KL4	15,00	3,15	1436	1460	3120	1248	312	37-38	51
		82,0	17,78	KL4	15,00	3,60	1250	1460	3120	1248	312	37-38	51
		31,0	46,84	KL3	15,00	0,95	3292	1460	2860	1144	241	37-38	51
		36,0	40,03	KL3	15,00	1,10	2813	1460	2860	1144	241	37-38	51
		42,0	34,54	KL3	15,00	1,30	2427	1460	2560	1024	241	37-38	51
		49,0	30,02	KL3	15,00	1,50	2109	1460	2560	1024	241	37-38	51
		56,0	26,23	KL3	15,00	1,70	1843	1460	2560	1024	241	37-38	51
		59,0	24,60	KL3	15,00	1,80	1729	1460	2560	1024	241	37-38	51
		63,0	23,00	KL3	15,00	1,95	1617	1460	2220	888	241	37-38	51

Potencia Entrada		Velocidad Salida aprox.	Relación	MODELO		Factor de Seguridad	Momento Util	Velocidad Entrada aprox.	Carga Radial adm.	Carga Axial adm.	Peso aprox.	Medidas	Repuestos
kW	HP	(RPM)	(i)			(fz)	(Nm)	(RPM)	(kg)	(kg)	(kg)	Página	Página
11,00 kW	15,00 HP	70,0	20,76	KL3	15,00	2,15	1459	1460	2220	888	241	37-38	51
		82,0	17,74	KL3	15,00	2,45	1247	1460	1740	696	241	37-38	51
		95,0	15,31	KL3	15,00	2,75	1076	1460	1740	696	241	37-38	51
		110,0	13,30	KL3	15,00	3,05	935	1460	1740	696	241	37-38	51
		126,0	11,62	KL3	15,00	3,40	817	1460	1610	644	241	37-38	51
		143,0	10,19	KL3	15,00	3,80	716	1460	1610	644	241	37-38	51
		161,0	9,08	KL3	15,00	3,45	638	1460	1280	512	241	37-38	51
		184,0	7,93	KL3	15,00	3,95	557	1460	1280	512	241	37-38	51
		70,0	20,77	KL2	15,00	1,05	1460	1460	1460	584	181	37-38	51
		77,0	18,93	KL2	15,00	1,15	1330	1460	1460	584	181	37-38	51
		83,0	17,59	KL2	15,00	1,20	1236	1460	1150	460	181	37-38	51
		94,0	15,58	KL2	15,00	1,35	1095	1460	1150	460	181	37-38	51
		97,0	15,02	KL2	15,00	1,40	1055	1460	1150	460	181	37-38	51
		112,0	13,04	KL2	15,00	1,60	916	1460	1150	460	181	37-38	51
		132,0	11,04	KL2	15,00	1,80	776	1460	1050	420	181	37-38	51
155,0	9,43	KL2	15,00	2,05	662	1460	1050	420	181	37-38	51		

Potencia Entrada		Velocidad Salida aprox.	Relación	MODELO		Factor de Seguridad	Momento Util	Velocidad Entrada aprox.	Carga Radial adm.	Carga Axial adm.	Peso aprox.	Medidas	Repuestos
kW	HP	(RPM)	(i)			(fz)	(Nm)	(RPM)	(kg)	(kg)	(kg)	Página	Página
15,00 kW	20,00 HP	9,2	158,89	KL5HR	20,00	0,95	14603	1465	9500	3800	666	39-40	51
		10,7	136,79	KL5HR	20,00	1,10	12572	1465	9500	3800	666	39-40	51
		12,4	118,58	KL5HR	20,00	1,25	10899	1465	9500	3800	666	39-40	51
		14,6	100,63	KL5HR	20,00	1,45	9249	1465	9500	3800	666	39-40	51
		16,9	86,52	KL5HR	20,00	1,70	7952	1465	9500	3800	666	39-40	51
		9,5	102,41	KL5	20,00 /6	1,00	14442	970	9500	3800	691	37-38	51
		11,6	83,37	KL5	20,00 /6	1,20	11757	970	9500	3800	691	37-38	51
		14,0	69,52	KL5	20,00 /6	1,45	9803	970	9500	3800	691	37-38	51
		16,4	58,99	KL5	20,00 /6	1,70	8319	970	9500	3800	691	37-38	51
		19,1	50,72	KL5	20,00 /6	2,00	7152	970	9500	3800	691	37-38	51
		22,0	44,05	KL5	20,00 /6	2,30	6212	970	9470	3788	691	37-38	51
		25,2	38,55	KL5	20,00 /6	2,65	5437	970	9470	3788	691	37-38	51
		26,3	36,94	KL5	20,00 /6	2,75	5210	970	9470	3788	691	37-38	51
		28,6	33,95	KL5	20,00 /6	3,00	4788	970	9470	3788	691	37-38	51
		31,5	30,80	KL5	20,00 /6	3,30	4344	970	9470	3788	691	37-38	51
		37,1	26,14	KL5	20,00 /6	3,95	3686	970	9470	3788	691	37-38	51
		14,0	102,41	KL5	20,00	1,50	9563	1465	9500	3800	646	37-38	51
		18,0	83,37	KL5	20,00	1,85	7784	1465	9500	3800	646	37-38	51
		21,0	69,52	KL5	20,00	2,20	6491	1465	9470	3788	646	37-38	51
		25,0	58,99	KL5	20,00	2,55	5508	1465	9470	3788	646	37-38	51
		29,0	50,72	KL5	20,00	3,00	4736	1465	9470	3788	646	37-38	51
		33,0	44,05	KL5	20,00	3,45	4113	1465	9470	3788	646	37-38	51
		38,0	38,55	KL5	20,00	3,95	3600	1465	9470	3788	646	37-38	51
		16,4	89,42	KL45	20,00	0,95	8350	1465	7070	2828	451	37-38	51
		20,3	72,17	KL45	20,00	1,15	6738	1465	7070	2828	451	37-38	51
		21,6	67,80	KL45	20,00	1,25	6331	1465	5840	2336	451	37-38	51
		24,6	59,62	KL45	20,00	1,40	5567	1465	5840	2336	451	37-38	51
		29,3	50,08	KL45	20,00	1,65	4676	1465	5840	2336	451	37-38	51
		34,4	42,58	KL45	20,00	1,95	3976	1465	5840	2336	451	37-38	51

Potencia Entrada		Velocidad Salida aprox.	Relación	MODELO		Factor de Seguridad	Momento Util	Velocidad Entrada aprox.	Carga Radial adm.	Carga Axial adm.	Peso aprox.	Medidas	Repuestos
kW	HP	(RPM)	(i)			(fz)	(Nm)	(RPM)	(kg)	(kg)	(kg)	Página	Página
15,00 kW	20,00 HP	37,0	39,63	KL45	20,00	2,10	3700	1465	5840	2336	451	37-38	51
		40,1	36,54	KL45	20,00	2,30	3412	1465	5840	2336	451	37-38	51
		46,4	31,56	KL45	20,00	2,65	2947	1465	4930	1972	451	37-38	51
		53,5	27,39	KL45	20,00	3,05	2558	1465	4930	1972	451	37-38	51
		55,5	26,42	KL45	20,00	3,15	2467	1465	4930	1972	451	37-38	51
		66,0	22,19	KL45	20,00	3,75	2072	1465	4070	1628	451	37-38	51
		31,8	46,11	KL4	20,00	1,05	4306	1465	4020	1608	337	37-38	51
		34,0	42,78	KL4	20,00	1,10	3995	1465	4020	1608	337	37-38	51
		37,0	40,13	KL4	20,00	1,20	3747	1465	4020	1608	337	37-38	51
		42,0	35,20	KL4	20,00	1,35	3287	1465	3600	1440	337	37-38	51
		44,0	33,42	KL4	20,00	1,45	3120	1465	3600	1440	337	37-38	51
		47,0	31,07	KL4	20,00	1,55	2901	1465	3600	1440	337	37-38	51
		53,0	27,56	KL4	20,00	1,75	2573	1465	3600	1440	337	37-38	51
		62,0	23,72	KL4	20,00	2,05	2215	1465	3600	1440	337	37-38	51
		72,0	20,43	KL4	20,00	2,35	1908	1465	3120	1248	337	37-38	51
82,0	17,78	KL4	20,00	2,70	1660	1465	3120	1248	337	37-38	51		
94,0	15,60	KL4	20,00	3,10	1456	1465	2450	980	337	37-38	51		
106,0	13,77	KL4	20,00	3,50	1285	1465	2450	980	337	37-38	51		
120,0	12,21	KL4	20,00	3,95	1140	1465	2450	980	337	37-38	51		
42,0	34,54	KL3	20,00	0,95	3225	1465	2560	1024	266	37-38	51		
49,0	30,02	KL3	20,00	1,10	2803	1465	2560	1024	266	37-38	51		
56,0	26,23	KL3	20,00	1,30	2449	1465	2560	1024	266	37-38	51		
60,0	24,60	KL3	20,00	1,35	2297	1465	2560	1024	266	37-38	51		
64,0	23,00	KL3	20,00	1,45	2148	1465	2220	888	266	37-38	51		
71,0	20,76	KL3	20,00	1,60	1938	1465	2220	888	266	37-38	51		
83,0	17,74	KL3	20,00	1,85	1656	1465	1740	696	266	37-38	51		
96,0	15,31	KL3	20,00	2,05	1429	1465	1740	696	266	37-38	51		

Potencia Entrada		Velocidad Salida aprox.	Relación	MODELO		Factor de Seguridad	Momento Util	Velocidad Entrada aprox.	Carga Radial adm.	Carga Axial adm.	Peso aprox.	Medidas	Repuestos
kW	HP	(RPM)	(i)			(fz)	(Nm)	(RPM)	(kg)	(kg)	(kg)	Página	Página
15,00 kW	20,00 HP	110,0	13,30	KL3	20,00	2,30	1242	1465	1740	696	266	37-38	51
		126,0	11,62	KL3	20,00	2,55	1085	1465	1610	644	266	37-38	51
		144,0	10,19	KL3	20,00	2,85	952	1465	1610	644	266	37-38	51
		161,0	9,08	KL3	20,00	2,60	848	1465	1280	512	266	37-38	51
		185,0	7,93	KL3	20,00	2,95	741	1465	1280	512	266	37-38	51
		211,0	6,96	KL3	20,00	3,40	650	1465	1280	512	266	37-38	51
		94,0	15,58	KL2	20,00	1,05	1455	1465	1150	460	206	37-38	51
		98,0	15,02	KL2	20,00	1,05	1403	1465	1150	460	206	37-38	51
		112,0	13,04	KL2	20,00	1,20	1217	1465	1150	460	206	37-38	51
		133,0	11,04	KL2	20,00	1,35	1031	1465	1050	420	206	37-38	51
		155,0	9,43	KL2	20,00	1,55	880	1465	1050	420	206	37-38	51

Potencia Entrada		Velocidad Salida aprox.	Relación	MODELO		Factor de Seguridad	Momento Util	Velocidad Entrada aprox.	Carga Radial adm.	Carga Axial adm.	Peso aprox.	Medidas	Repuestos
kW	HP	(RPM)	(i)			(fz)	(Nm)	(RPM)	(kg)	(kg)	(kg)	Página	Página

18,50 kW
25,00 HP

		12,8	118,58	KL5HR	25,00	1,00	13624	1465	9500	3800	697	39-40	51
		14,8	100,63	KL5HR	25,00	1,20	11561	1465	9500	3800	697	39-40	51
		16,9	86,52	KL5HR	25,00	1,35	9940	1465	9500	3800	697	39-40	51
		11,7	83,37	KL5	25,00 /6	1,00	14620	975	9500	3800	715	37-38	51
		14,0	69,52	KL5	25,00 /6	1,15	12191	975	9500	3800	715	37-38	51
		16,5	58,99	KL5	25,00 /6	1,35	10345	975	9500	3800	715	37-38	51
		19,2	50,72	KL5	25,00 /6	1,60	8895	975	9500	3800	715	37-38	51
		22,1	44,05	KL5	25,00 /6	1,85	7725	975	9470	3788	715	37-38	51
		25,3	38,55	KL5	25,00 /6	2,10	6762	975	9470	3788	715	37-38	51
		26,4	36,94	KL5	25,00 /6	2,20	6479	975	9470	3788	715	37-38	51
		28,7	33,95	KL5	25,00 /6	2,40	5954	975	9470	3788	715	37-38	51
		31,7	30,80	KL5	25,00 /6	2,65	5402	975	9470	3788	715	37-38	51
		37,3	26,14	KL5	25,00 /6	3,15	4584	975	9470	3788	715	37-38	51
		14,0	102,41	KL5	25,00	1,20	11953	1465	9500	3800	677	37-38	51
		18,0	83,37	KL5	25,00	1,45	9730	1465	9500	3800	677	37-38	51
		21,0	69,52	KL5	25,00	1,75	8114	1465	9470	3788	677	37-38	51
		25,0	58,99	KL5	25,00	2,05	6885	1465	9470	3788	677	37-38	51
		29,0	50,72	KL5	25,00	2,40	5920	1465	9470	3788	677	37-38	51
		33,0	44,05	KL5	25,00	2,75	5141	1465	9470	3788	677	37-38	51
		38,0	38,55	KL5	25,00	3,20	4500	1465	9470	3788	677	37-38	51
		40,0	36,94	KL5	25,00	3,30	4312	1465	9470	3788	677	37-38	51
		43,0	33,95	KL5	25,00	3,60	3963	1465	7410	2964	677	37-38	51
		48,0	30,80	KL5	25,00	4,00	3595	1465	7410	2964	677	37-38	51
		21,6	67,80	KL45	25,00	1,00	7913	1465	5840	2336	482	37-38	51
		24,6	59,62	KL45	25,00	1,10	6958	1465	5840	2336	482	37-38	51
		29,3	50,08	KL45	25,00	1,35	5845	1465	5840	2336	482	37-38	51
		34,4	42,58	KL45	25,00	1,55	4970	1465	5840	2336	482	37-38	51

Potencia Entrada		Velocidad Salida aprox.	Relación	MODELO		Factor de Seguridad	Momento Util	Velocidad Entrada aprox.	Carga Radial adm.	Carga Axial adm.	Peso aprox.	Medidas	Repuestos
kW	HP	(RPM)	(i)			(fz)	(Nm)	(RPM)	(kg)	(kg)	(kg)	Página	Página

18,50 kW
25,00 HP

		37,0	39,63	KL45	25,00	1,70	4625	1465	5840	2336	482	37-38	51
		40,1	36,54	KL45	25,00	1,80	4265	1465	5840	2336	482	37-38	51
		46,4	31,56	KL45	25,00	2,10	3684	1465	4930	1972	482	37-38	51
		53,5	27,39	KL45	25,00	2,45	3197	1465	4930	1972	482	37-38	51
		55,5	26,42	KL45	25,00	2,50	3083	1465	4930	1972	482	37-38	51
		66,0	22,19	KL45	25,00	3,00	2590	1465	4070	1628	482	37-38	51
		77,6	18,87	KL45	25,00	3,45	2202	1465	4070	1628	482	37-38	51
		90,5	16,19	KL45	25,00	3,85	1890	1465	3520	1408	482	37-38	51
		37,0	40,13	KL4	25,00	0,95	4684	1465	4020	1608	368	37-38	51
		42,0	35,20	KL4	25,00	1,10	4108	1465	3600	1440	368	37-38	51
		47,0	31,07	KL4	25,00	1,25	3626	1465	3600	1440	368	37-38	51
		53,0	27,56	KL4	25,00	1,40	3216	1465	3600	1440	368	37-38	51
		62,0	23,72	KL4	25,00	1,60	2769	1465	3600	1440	368	37-38	51
		72,0	20,43	KL4	25,00	1,90	2385	1465	3120	1248	368	37-38	51
		82,0	17,78	KL4	25,00	2,15	2075	1465	3120	1248	368	37-38	51
		94,0	15,60	KL4	25,00	2,45	1820	1465	2450	980	368	37-38	51
		106,0	13,77	KL4	25,00	2,80	1607	1465	2450	980	368	37-38	51
		120,0	12,21	KL4	25,00	3,15	1425	1465	2450	980	368	37-38	51
		138,0	10,59	KL4	25,00	3,65	1237	1465	2260	904	368	37-38	51
		56,0	26,23	KL3	25,00	1,00	3061	1465	2560	1024	297	37-38	51
		64,0	23,00	KL3	25,00	1,15	2685	1465	2220	888	297	37-38	51
		71,0	20,76	KL3	25,00	1,30	2423	1465	2220	888	297	37-38	51
		83,0	17,74	KL3	25,00	1,45	2071	1465	1740	696	297	37-38	51
		96,0	15,31	KL3	25,00	1,65	1786	1465	1740	696	297	37-38	51
		110,0	13,30	KL3	25,00	1,85	1552	1465	1740	696	297	37-38	51
		126,0	11,62	KL3	25,00	2,05	1356	1465	1610	644	297	37-38	51
		144,0	10,19	KL3	25,00	2,25	1190	1465	1610	644	297	37-38	51
		161,0	9,08	KL3	25,00	2,10	1060	1465	1280	512	297	37-38	51
		185,0	7,93	KL3	25,00	2,40	926	1465	1280	512	297	37-38	51
		211,0	6,96	KL3	25,00	2,70	812	1465	1280	512	297	37-38	51

Potencia Entrada		Velocidad Salida aprox.	Relación	MODELO		Factor de Seguridad	Momento Util	Velocidad Entrada aprox.	Carga Radial adm.	Carga Axial adm.	Peso aprox.	Medidas	Repuestos
kW	HP	(RPM)	(i)			(fz)	(Nm)	(RPM)	(kg)	(kg)	(kg)	Página	Página

22,00 kW
30,00 HP

		14,6	100,63	KL5HR	30,00	1,00	13873	1465	9500	3800	709	39-40	51
		16,9	86,52	KL5HR	30,00	1,15	11928	1465	9500	3800	709	39-40	51
		14,0	102,41	KL5	30,00	1,00	14344	1465	9500	3800	689	37-38	51
		18,0	83,37	KL5	30,00	1,20	11676	1465	9500	3800	689	37-38	51
		21,0	69,52	KL5	30,00	1,45	9736	1465	9470	3788	689	37-38	51
		25,0	58,99	KL5	30,00	1,70	8262	1465	9470	3788	689	37-38	51
		29,0	50,72	KL5	30,00	2,00	7104	1465	9470	3788	689	37-38	51
		33,0	44,05	KL5	30,00	2,30	6169	1465	9470	3788	689	37-38	51
		38,0	38,55	KL5	30,00	2,65	5400	1465	9470	3788	689	37-38	51
		40,0	36,94	KL5	30,00	2,75	5174	1465	9470	3788	689	37-38	51
		43,0	33,95	KL5	30,00	3,00	4755	1465	7410	2964	689	37-38	51
		48,0	30,80	KL5	30,00	3,30	4314	1465	7410	2964	689	37-38	51
		56,0	26,14	KL5	30,00	3,95	3661	1465	7410	2964	689	37-38	51
		24,6	59,62	KL45	30,00	0,95	8350	1465	5840	2336	494	37-38	51
		29,3	50,08	KL45	30,00	1,10	7014	1465	5840	2336	494	37-38	51
		34,4	42,58	KL45	30,00	1,30	5964	1465	5840	2336	494	37-38	51
		37,0	39,63	KL45	30,00	1,40	5550	1465	5840	2336	494	37-38	51
		40,1	36,54	KL45	30,00	1,50	5118	1465	5840	2336	494	37-38	51
		46,4	31,56	KL45	30,00	1,75	4421	1465	4930	1972	494	37-38	51
		53,5	27,39	KL45	30,00	2,05	3836	1465	4930	1972	494	37-38	51
		55,5	26,42	KL45	30,00	2,10	3700	1465	4930	1972	494	37-38	51
		66,0	22,19	KL45	30,00	2,50	3108	1465	4070	1628	494	37-38	51
		77,6	18,87	KL45	30,00	2,85	2643	1465	4070	1628	494	37-38	51
		90,5	16,19	KL45	30,00	3,20	2268	1465	3520	1408	494	37-38	51
		104,8	13,99	KL45	30,00	3,60	1959	1465	3520	1408	494	37-38	51
		47,0	31,07	KL4	30,00	1,05	4351	1465	3600	1440	380	37-38	51
		53,0	27,56	KL4	30,00	1,15	3859	1465	3600	1440	380	37-38	51

Potencia Entrada		Velocidad Salida aprox.	Relación	MODELO		Factor de Seguridad	Momento Util	Velocidad Entrada aprox.	Carga Radial adm.	Carga Axial adm.	Peso aprox.	Medidas	Repuestos
kW	HP	(RPM)	(i)			(fz)	(Nm)	(RPM)	(kg)	(kg)	(kg)	Página	Página

22,00 kW
30,00 HP

		62,0	23,72	KL4	30,00	1,35	3323	1465	3600	1440	380	37-38	51
		72,0	20,43	KL4	30,00	1,55	2862	1465	3120	1248	380	37-38	51
		82,0	17,78	KL4	30,00	1,80	2490	1465	3120	1248	380	37-38	51
		94,0	15,60	KL4	30,00	2,05	2185	1465	2450	980	380	37-38	51
		106,0	13,77	KL4	30,00	2,35	1928	1465	2450	980	380	37-38	51
		120,0	12,21	KL4	30,00	2,60	1710	1465	2450	980	380	37-38	51
		138,0	10,59	KL4	30,00	3,00	1484	1465	2260	904	380	37-38	51
		157,0	9,35	KL4	30,00	3,40	1310	1465	1520	608	380	37-38	51
		177,0	8,29	KL4	30,00	3,85	1162	1465	1520	608	380	37-38	51
		64,0	23,00	KL3	30,00	0,95	3222	1465	2220	888	309	37-38	51
		71,0	20,76	KL3	30,00	1,10	2907	1465	2220	888	309	37-38	51
		83,0	17,74	KL3	30,00	1,25	2485	1465	1740	696	309	37-38	51
		96,0	15,31	KL3	30,00	1,40	2144	1465	1740	696	309	37-38	51
		110,0	13,30	KL3	30,00	1,55	1863	1465	1740	696	309	37-38	51
		126,0	11,62	KL3	30,00	1,70	1628	1465	1610	644	309	37-38	51
		144,0	10,19	KL3	30,00	1,90	1428	1465	1610	644	309	37-38	51
		161,0	9,08	KL3	30,00	1,75	1272	1465	1280	512	309	37-38	51
		185,0	7,93	KL3	30,00	2,00	1111	1465	1280	512	309	37-38	51
		211,0	6,96	KL3	30,00	2,25	975	1465	1280	512	309	37-38	51

Potencia Entrada		Velocidad Salida aprox.	Relación	MODELO		Factor de Seguridad	Momento Util	Velocidad Entrada aprox.	Carga Radial adm.	Carga Axial adm.	Peso aprox.	Medidas	Repuestos
kW	HP	(RPM)	(i)			(fz)	(Nm)	(RPM)	(kg)	(kg)	(kg)	Página	Página
30,00 kW	40,00 HP	21,0	69,52	KL5	40,00	1,10	12938	1470	9470	3788	737	37-38	51
		25,0	58,99	KL5	40,00	1,30	10979	1470	9470	3788	737	37-38	51
		29,0	50,72	KL5	40,00	1,50	9439	1470	9470	3788	737	37-38	51
		33,0	44,05	KL5	40,00	1,75	8198	1470	9470	3788	737	37-38	51
		38,0	38,55	KL5	40,00	2,00	7176	1470	9470	3788	737	37-38	51
		40,0	36,94	KL5	40,00	2,10	6875	1470	9470	3788	737	37-38	51
		43,0	33,95	KL5	40,00	2,25	6319	1470	7410	2964	737	37-38	51
		48,0	30,80	KL5	40,00	2,50	5733	1470	7410	2964	737	37-38	51
		56,0	26,14	KL5	40,00	2,95	4865	1470	7410	2964	737	37-38	51
		65,0	22,47	KL5	40,00	3,15	4183	1470	6090	2436	737	37-38	51
		75,0	19,52	KL5	40,00	3,35	3633	1470	6090	2436	737	37-38	51
		86,0	17,08	KL5	40,00	3,50	3180	1470	5090	2036	737	37-38	51
		98,0	15,05	KL5	40,00	3,70	2800	1470	5090	2036	737	37-38	51
		113,0	13,04	KL5	40,00	3,90	2427	1470	5090	2036	737	37-38	51
		34,5	42,58	KL45	40,00	1,00	7925	1470	5840	2336	542	37-38	51
		37,1	39,63	KL45	40,00	1,05	7375	1470	5840	2336	542	37-38	51
		40,2	36,54	KL45	40,00	1,15	6800	1470	5840	2336	542	37-38	51
		46,6	31,56	KL45	40,00	1,30	5874	1470	4930	1972	542	37-38	51
		53,7	27,39	KL45	40,00	1,50	5098	1470	4930	1972	542	37-38	51
		55,6	26,42	KL45	40,00	1,60	4917	1470	4930	1972	542	37-38	51
		66,2	22,19	KL45	40,00	1,90	4130	1470	4070	1628	542	37-38	51
		77,9	18,87	KL45	40,00	2,15	3512	1470	4070	1628	542	37-38	51
		90,8	16,19	KL45	40,00	2,40	3013	1470	3520	1408	542	37-38	51
		105,1	13,99	KL45	40,00	2,70	2603	1470	3520	1408	542	37-38	51
		121,1	12,14	KL45	40,00	2,95	2259	1470	3520	1408	542	37-38	51
		131,7	11,16	KL45	40,00	3,05	2077	1470	3140	1256	542	37-38	51
		153,5	9,57	KL45	40,00	3,45	1782	1470	3140	1256	542	37-38	51
		177,7	8,27	KL45	40,00	3,95	1539	1470	2275	910	542	37-38	51

Potencia Entrada		Velocidad Salida aprox.	Relación	MODELO		Factor de Seguridad	Momento Util	Velocidad Entrada aprox.	Carga Radial adm.	Carga Axial adm.	Peso aprox.	Medidas	Repuestos
kW	HP	(RPM)	(i)			(fz)	(Nm)	(RPM)	(kg)	(kg)	(kg)	Página	Página
37,00 kW	50,00 HP	25,0	58,99	KL5	50,00	1,05	13677	1475	9470	3788	867	37-38	51
		29,0	50,72	KL5	50,00	1,20	11759	1475	9470	3788	867	37-38	51
		33,0	44,05	KL5	50,00	1,40	10213	1475	9470	3788	867	37-38	51
		38,0	38,55	KL5	50,00	1,60	8939	1475	9470	3788	867	37-38	51
		43,0	33,95	KL5	50,00	1,80	7872	1475	7410	2964	867	37-38	51
		48,0	30,80	KL5	50,00	2,00	7142	1475	7410	2964	867	37-38	51
		56,0	26,14	KL5	50,00	2,35	6061	1475	7410	2964	867	37-38	51
		66,0	22,47	KL5	50,00	2,50	5211	1475	6090	2436	867	37-38	51
		76,0	19,52	KL5	50,00	2,65	4525	1475	6090	2436	867	37-38	51
		86,0	17,08	KL5	50,00	2,80	3961	1475	5090	2036	867	37-38	51
		98,0	15,05	KL5	50,00	2,95	3488	1475	5090	2036	867	37-38	51
		113,0	13,04	KL5	50,00	3,10	3023	1475	5090	2036	867	37-38	51
		130,0	11,32	KL5	50,00	3,60	2626	1475	4430	1772	867	37-38	51
		46,7	31,56	KL45	50,00	1,05	7318	1475	4930	1972	672	37-38	51
		53,9	27,39	KL45	50,00	1,20	6351	1475	4930	1972	672	37-38	51
		55,8	26,42	KL45	50,00	1,25	6125	1475	4930	1972	672	37-38	51
		66,5	22,19	KL45	50,00	1,50	5145	1475	4070	1628	672	37-38	51
		78,2	18,87	KL45	50,00	1,70	4375	1475	4070	1628	672	37-38	51
		91,1	16,19	KL45	50,00	1,95	3754	1475	3520	1408	672	37-38	51
		105,5	13,99	KL45	50,00	2,15	3243	1475	3520	1408	672	37-38	51
		121,5	12,14	KL45	50,00	2,35	2814	1475	3520	1408	672	37-38	51
		132,2	11,16	KL45	50,00	2,40	2587	1475	3140	1256	672	37-38	51
		154,0	9,57	KL45	50,00	2,75	2220	1475	3140	1256	672	37-38	51
		178,3	8,27	KL45	50,00	3,20	1918	1475	2275	910	672	37-38	51
		205,5	7,18	KL45	50,00	3,65	1664	1475	2275	910	672	37-38	51

Potencia Entrada		Velocidad Salida aprox.	Relación	MODELO		Factor de Seguridad	Momento Util	Velocidad Entrada aprox.	Carga Radial adm.	Carga Axial adm.	Peso aprox.	Medidas	Repuestos		
kW	HP	(RPM)	(i)			(fz)	(Nm)	(RPM)	(kg)	(kg)	(kg)	Página	Página		
45,00 kW	60,00 HP	29,0	50,72	KL5	60,00	1,00	14111	1475	9470	3788	888	37-38	51		
		33,0	44,05	KL5	60,00	1,15	12255	1475	9470	3788	888	37-38	51		
		38,0	38,55	KL5	60,00	1,30	10727	1475	9470	3788	888	37-38	51		
		43,0	33,95	KL5	60,00	1,50	9446	1475	7410	2964	888	37-38	51		
		48,0	30,80	KL5	60,00	1,65	8570	1475	7410	2964	888	37-38	51		
		56,0	26,14	KL5	60,00	1,95	7273	1475	7410	2964	888	37-38	51		
		66,0	22,47	KL5	60,00	2,10	6253	1475	6090	2436	888	37-38	51		
		76,0	19,52	KL5	60,00	2,20	5431	1475	6090	2436	888	37-38	51		
		86,0	17,08	KL5	60,00	2,35	4753	1475	5090	2036	888	37-38	51		
		98,0	15,05	KL5	60,00	2,45	4186	1475	5090	2036	888	37-38	51		
		113,0	13,04	KL5	60,00	2,60	3628	1475	5090	2036	888	37-38	51		
		130,0	11,32	KL5	60,00	3,00	3151	1475	4430	1772	888	37-38	51		
		149,0	9,91	KL5	60,00	3,40	2758	1475	4430	1772	888	37-38	51		
		169,0	8,73	KL5	60,00	3,85	2429	1475	3220	1288	888	37-38	51		
				53,9	27,39	KL45	60,00	1,00	7621	1475	4930	1972	693	37-38	51
				55,8	26,42	KL45	60,00	1,05	7350	1475	4930	1972	693	37-38	51
				66,5	22,19	KL45	60,00	1,25	6174	1475	4070	1628	693	37-38	51
				78,2	18,87	KL45	60,00	1,45	5250	1475	4070	1628	693	37-38	51
				91,1	16,19	KL45	60,00	1,60	4505	1475	3520	1408	693	37-38	51
				105,5	13,99	KL45	60,00	1,80	3891	1475	3520	1408	693	37-38	51
		121,5	12,14	KL45	60,00	1,95	3377	1475	3520	1408	693	37-38	51		
		132,2	11,16	KL45	60,00	2,00	3105	1475	3140	1256	693	37-38	51		
		154,0	9,57	KL45	60,00	2,30	2664	1475	3140	1256	693	37-38	51		
		178,3	8,27	KL45	60,00	2,65	2301	1475	2275	910	693	37-38	51		
		205,5	7,18	KL45	60,00	3,05	1997	1475	2275	910	693	37-38	51		

Potencia Entrada		Velocidad Salida aprox.	Relación	MODELO		Factor de Seguridad	Momento Util	Velocidad Entrada aprox.	Carga Radial adm.	Carga Axial adm.	Peso aprox.	Medidas	Repuestos
kW	HP	(RPM)	(i)			(fz)	(Nm)	(RPM)	(kg)	(kg)	(kg)	Página	Página
55,00 kW	75,00 HP	38,0	38,55	KL5	75,00	1,05	13409	1475	9470	3788	956	37-38	51
		43,0	33,95	KL5	75,00	1,20	11808	1475	7410	2964	956	37-38	51
		48,0	30,80	KL5	75,00	1,35	10713	1475	7410	2964	956	37-38	51
		56,0	26,14	KL5	75,00	1,55	9091	1475	7410	2964	956	37-38	51
		66,0	22,47	KL5	75,00	1,65	7816	1475	6090	2436	956	37-38	51
		76,0	19,52	KL5	75,00	1,80	6788	1475	6090	2436	956	37-38	51
		86,0	17,08	KL5	75,00	1,85	5942	1475	5090	2036	956	37-38	51
		98,0	15,05	KL5	75,00	2,00	5232	1475	5090	2036	956	37-38	51
		113,0	13,04	KL5	75,00	2,05	4535	1475	5090	2036	956	37-38	51
		130,0	11,32	KL5	75,00	2,40	3938	1475	4430	1772	956	37-38	51
149,0	9,91	KL5	75,00	2,70	3447	1475	4430	1772	956	37-38	51		
169,0	8,73	KL5	75,00	3,10	3036	1475	3220	1288	956	37-38	51		

Potencia Entrada		Velocidad Salida aprox.	Relación	MODELO		Factor de Seguridad	Momento Util	Velocidad Entrada aprox.	Carga Radial adm.	Carga Axial adm.	Peso aprox.	Medidas	Repuestos
kW	HP	(RPM)	(i)			(fz)	(Nm)	(RPM)	(kg)	(kg)	(kg)	Página	Página
75,00 kW	100,00 HP	48,0	30,80	KL5	100,0	1,00	14188	1485	7410	2964	1164	37-38	51
		57,0	26,14	KL5	100,0	1,20	12039	1485	7410	2964	1164	37-38	51
		66,0	22,47	KL5	100,0	1,25	10351	1485	6090	2436	1164	37-38	51
		76,0	19,52	KL5	100,0	1,35	8990	1485	6090	2436	1164	37-38	51
		87,0	17,08	KL5	100,0	1,40	7869	1485	5090	2036	1164	37-38	51
		99,0	15,05	KL5	100,0	1,50	6930	1485	5090	2036	1164	37-38	51
		114,0	13,04	KL5	100,0	1,55	6006	1485	5090	2036	1164	37-38	51
		131,0	11,32	KL5	100,0	1,80	5216	1485	4430	1772	1164	37-38	51
		150,0	9,91	KL5	100,0	2,05	4565	1485	4430	1772	1164	37-38	51
170,0	8,73	KL5	100,0	2,30	4020	1485	3220	1288	1164	37-38	51		

TABLA DE MEDIDAS - SERIE " KL " (CON EJE DE SALIDA HUECO)
OVERALL DIMENSIONS - TYPE " KL " (WITH OUTPUT HOLLOW SHAFT)

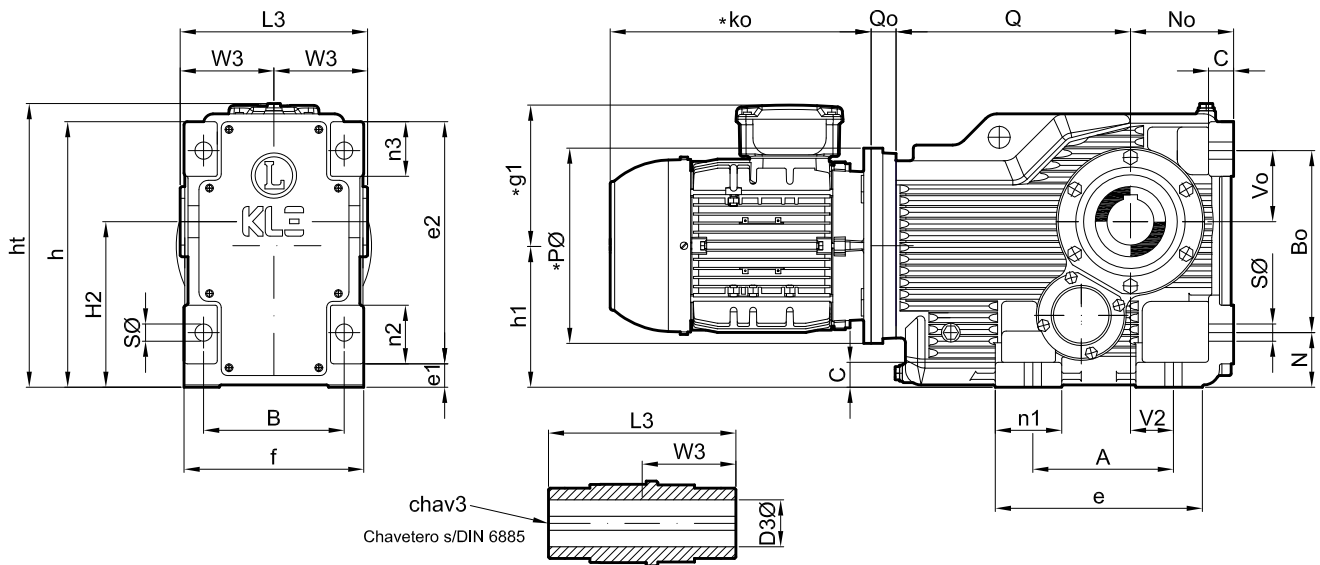

Modelo	D3 ϕ	L3	chav 3	W3	H2	A	B	Bo	C	S ϕ	Q	Qo				B1 ϕ	R1 ϕ	S1 ϕ	a1 ϕ	c1	f1	J		
				Tamaño Motor IEC / Motor Size																				
				80-90 100-112 132 160...200 225<																				
Model	keyway 3																							
KL2	mm	50	210	14x9	105	180	150	165	200	25	18	278	32	32	52	82	---	230	265	14	300	16	5	4
KL3	mm	60	240	18x11	120	212	180	180	233	32	22	300	32	32	52	82	---	250	300	18	350	18	5	4
KL4	mm	70	300	20x12	150	265	240	240	295	36	26	340	32	32	52	82	---	350	400	18	450	18	5	8
KL45	mm	90	350	25x14	175	315	270	270	360	40	33	378	---	45	45	75	105	350	400	18	450	18	5	8
KL5	mm	100	412	28x16	206	375	350	330	420	50	39	450	---	45	45	75	105	450	500	18	550	28	5	8

Modelo	N	No	Vo	V2	W1	Y	e	e1	e2	f	h	h1	ht	ht1	n1	n2	n3	n4	Peso kg Weight	aceite lts oil	
Model																					
KL2	mm	55	112	75	40	130	25	218	25	263	200	288	158,5	310	330	68	60	65	150	85	3,0
KL3	mm	70	132	91	55	150	30	265	30	310	230	340	181	365	387	85	75	70	175	145	5,0
KL4	mm	75	160	105	75	192	42	330	36	381	290	417	218	440	490	95	86	95	225	216	8,5
KL45	mm	95	200	140	95	216	41	380	45	465	340	503	264	525	524	115	100	115	225	330	15
KL5	mm	110	225	155	115	256	50	465	50	542	400	592	318	600	650	130	120	122	275	550	25

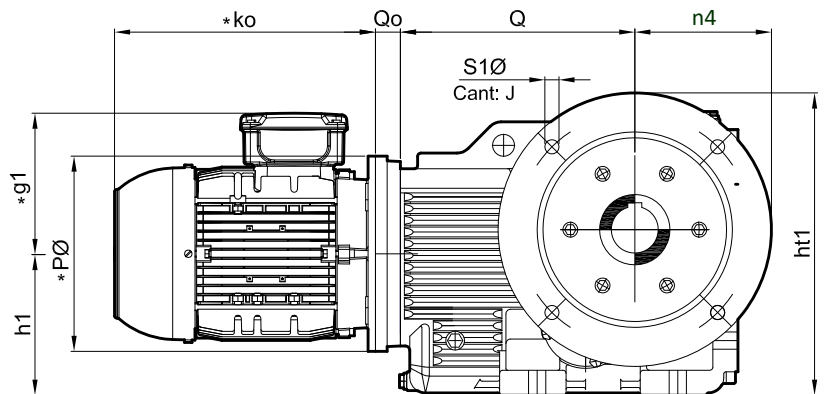
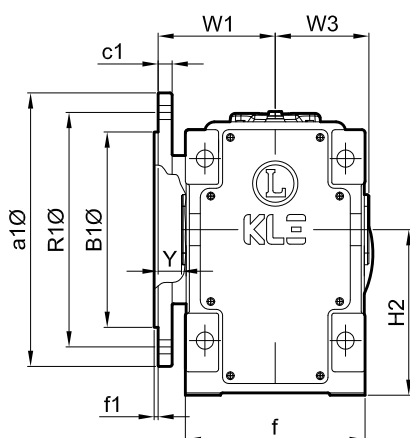

NOTA 1 : Las dimensiones son aproximadas pudiendo modificarse sin aviso previo.
 NOTE 1 : Dimensions are for reference only , unless certified.
 NOTA 2 : Las capacidades de lubricante son para posición 1A.
 NOTE 2 : Oil capacity valid only for mounting position 1A.

NOTA 3 : Para dimensiones ko, P y g1 ver pag. 41 ó catálogo de motores (I.E.C.).
 NOTE 3 : To determinate ko, P and g1 see page 41, or electrical motors catalogue (I.E.C.).
 NOTA 4 : Los pesos no incluyen peso del motor.
 NOTE 4 : Motor weight is not included.

TABLA DE MEDIDAS - SERIE " KL " (CON EJE DE SALIDA MACIZO)
OVERALL DIMENSIONS - TYPE " KL " (WITH OUTPUT SOLID SHAFT)

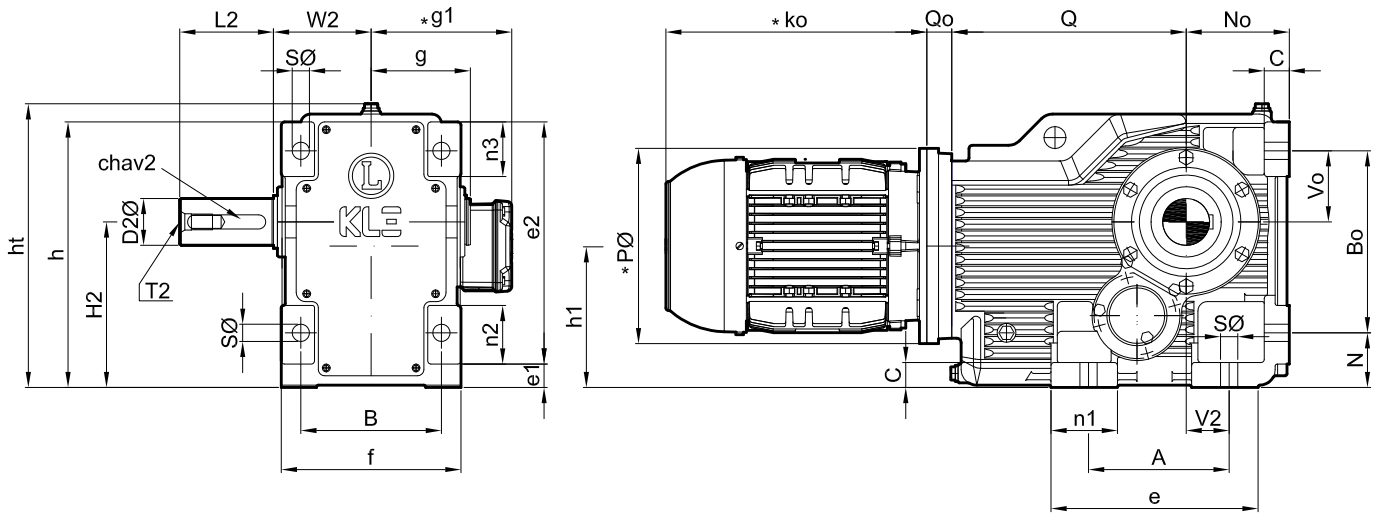

Modelo	D2Ø	L2	chav 2	T2	H2	A	B	Bø	C	SØ	Q	Tamaño Motor IEC / Motor Size					B1Ø	R1Ø	S1Ø	a1Ø	c1	f1	J	
Model	keway 2		80-90 100-112 132 160...200 225<																					
KL2	mm	50	100	14x9	M16	180	150	165	200	25	18	278	32	32	52	82	----	230	265	14	300	16	5	4
KL3	mm	60	120	18x11	M20	212	180	180	233	32	22	300	32	32	52	82	----	250	300	18	350	18	5	4
KL4	mm	70	140	20x12	M20	265	240	240	295	36	26	340	32	32	52	82	----	350	400	18	450	18	5	8
KL45	mm	90	170	25x14	M24	315	270	270	360	40	33	378	----	45	45	75	105	350	400	18	450	18	5	8
KL5	mm	100	190	28x16	M24	375	350	330	420	50	39	450	----	45	45	75	105	450	500	18	550	28	5	8

Modelo	N	No	Vo	V2	W1	W2	Y	e	e1	e2	f	g	h	h1	ht	ht1	n1	n2	n3	n4	Peso kg Weight	aceite lbs oil	
Model																							
KL2	mm	55	112	75	40	130	108	25	218	25	263	200	112	288	158,5	310	330	68	60	65	150	90	3,0
KL3	mm	70	132	91	55	150	125	30	265	30	310	230	127	340	181	365	387	85	75	70	175	153	5,0
KL4	mm	75	160	105	75	192	155	42	330	36	381	290	160	417	218	440	490	95	86	95	225	230	8,5
KL45	mm	95	200	140	95	216	182	41	380	45	465	340	185	503	264	525	524	115	100	115	225	359	15
KL5	mm	110	225	155	115	256	212	44	465	50	542	400	200	592	318	600	650	130	120	122	275	597	25

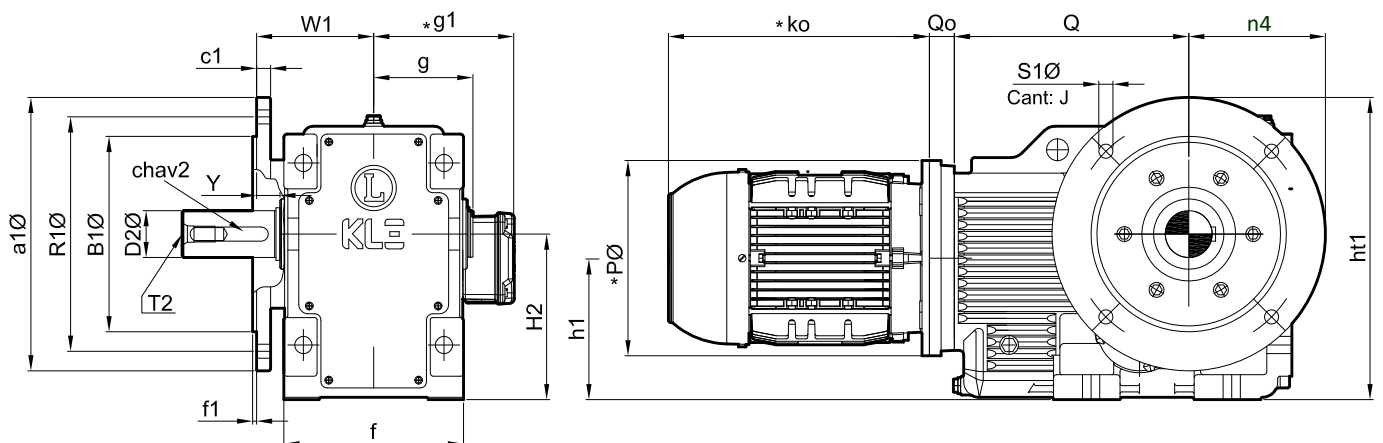

NOTA 1 : Las dimensiones son aproximadas pudiendo modificarse sin aviso previo.
 NOTE 1 : Dimensions are for reference only , unless certified.
 NOTA 2 : Las capacidades de lubricante son para posición 1A.
 NOTE 2 : Oil capacity valid only for mounting position 1A.

NOTA 3 : Para dimensiones ko, P y g1 ver pag. 41 ó catálogo de motores (I.E.C.).
 NOTE 3 : To determinate ko, P and g1 see page 41, or electrical motors catalogue (I.E.C.).
 NOTA 4 : Los pesos no incluyen peso del motor.
 NOTE 4 : Motor weight is not included.

TABLA DE MEDIDAS - SERIE " KL " (CON EJE DE SALIDA HUECO Y ANTECAJA DE SIMPLE REDUCCIÓN)
OVERALL DIMENSIONS - TYPE " KL " (WITH OUTPUT HOLLOW SHAFT AND PRIMARY ONE-STEP GEARBOX)

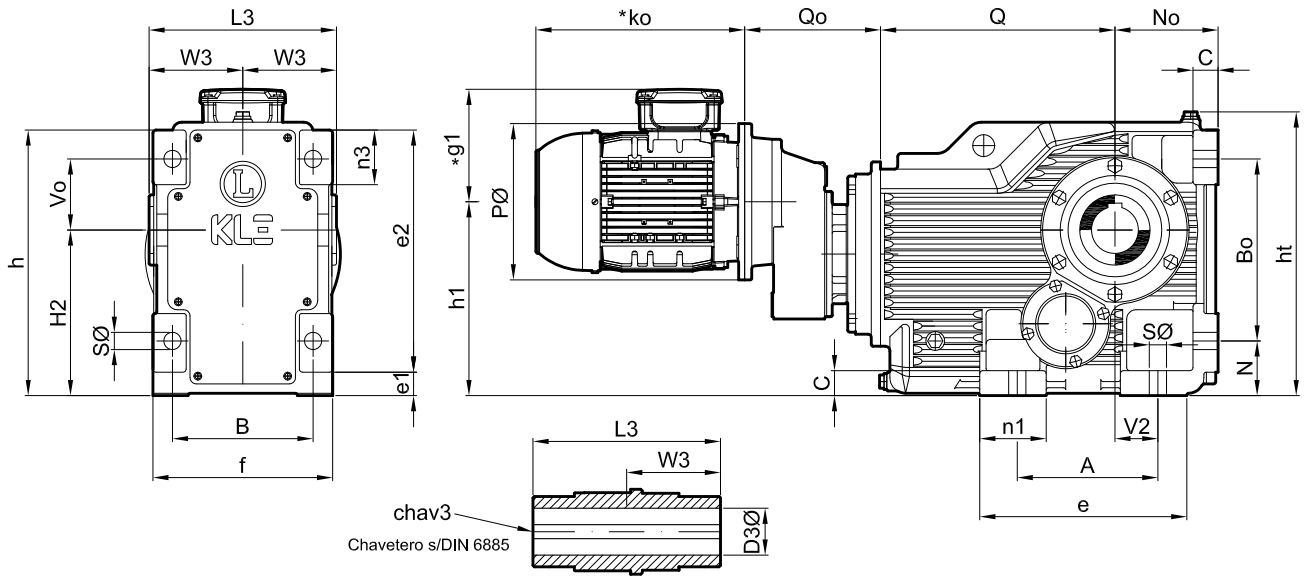

Modelo	D3Ø	L3	chav 3	W3	H2	A	B	Bo	C	SØ	Q	Tamaño Motor IEC / Motor Size					B1Ø	R1Ø	S1Ø	a1Ø	c1	f1	J	
												80-90	100	112	132	160-180								
KL2TR	mm	50	210	14x9	105	180	150	165	200	25	18	278	174	181	---	---	---	230	265	14	300	16	5	4
KL3TR	mm	60	240	18x11	120	212	180	233	32	22	300	174	181	181	---	---	250	300	18	350	18	5	4	
KL4TR	mm	70	300	20x12	150	265	240	295	36	26	340	174	181	181	---	---	350	400	18	450	18	5	8	
KL4HR	mm	70	300	20x12	150	265	240	295	36	26	340	---	204	204	224	---	350	400	18	450	18	5	8	
KL45HR	mm	90	350	25x14	175	315	270	360	40	33	378	217	217	217	237	267	350	400	18	450	18	5	8	
KL5HR	mm	100	412	28x16	206	375	350	420	50	39	450	217	217	217	237	267	450	500	18	550	28	5	8	

Modelo	N	No	Vo	V2	W1	Y	e	e1	e2	f	h	h1	ht	ht1	n1	n2	n3	n4	Peso	aceite	
																			kg	lbs	
KL2TR	mm	55	112	75	40	130	25	218	25	263	200	288	225,5	310	330	68	60	65	150	100	3,8
KL3TR	mm	70	132	91	55	150	30	265	30	310	230	340	248	365	387	85	75	70	175	160	5,8
KL4TR	mm	75	160	105	75	192	42	330	36	381	290	417	285	440	490	95	86	95	175	231	9,3
KL4HR	mm	75	160	105	75	192	42	330	36	381	290	417	304	440	490	95	86	95	225	236	10,0
KL45HR	mm	95	200	140	95	216	41	380	45	465	340	503	350	525	524	115	100	115	225	350	16,5
KL5HR	mm	110	225	155	115	256	50	465	50	542	400	592	404	600	650	130	120	122	275	570	26,5

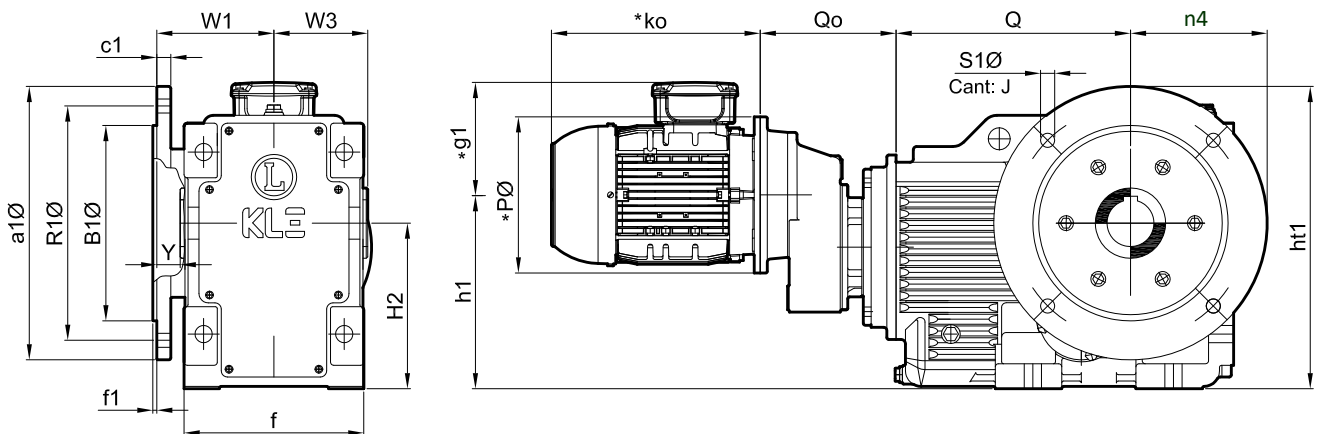

NOTA 1 : Las dimensiones son aproximadas pudiendo modificarse sin aviso previo.
 NOTE 1 : Dimensions are for reference only, unless certified.
 NOTA 2 : Las capacidades de lubricante son para posición 1A.
 NOTE 2 : Oil capacity valid only for mounting position 1A.

NOTA 3 : Para dimensiones ko, P y g1 ver pag. 41 ó catálogo de motores (I.E.C.).
 NOTE 3 : To determinate ko, P and g1 see page 41, or electrical motors catalogue (I.E.C.).
 NOTA 4 : Los pesos no incluyen peso del motor.
 NOTE 4 : Motor weight is not included.

TABLA DE MEDIDAS - SERIE " KL " (CON EJE DE SALIDA MACIZO Y ANTECAJA DE SIMPLE REDUCCIÓN)
OVERALL DIMENSIONS - TYPE " KL " (WITH OUTPUT SOLID SHAFT AND PRIMARY ONE-STEP GEARBOX)

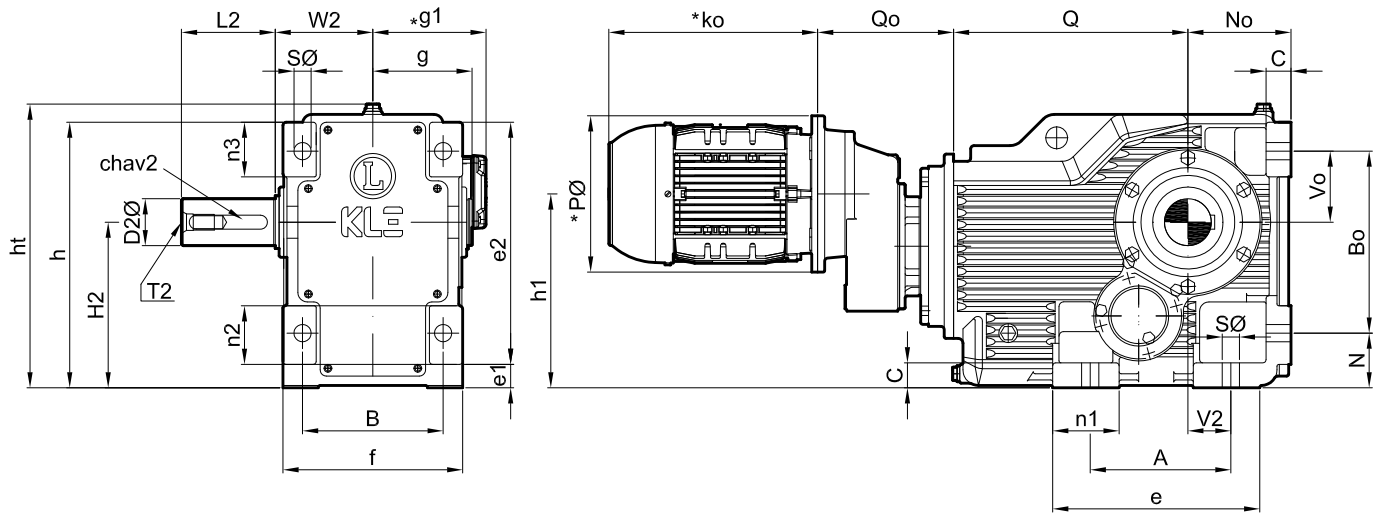

Modelo	D2Ø	L2	chav 2	T2	H2	A	B	Bo	C	SØ	Q	Tamaño Motor IEC / Motor Size					B1Ø	R1Ø	S1Ø	a1Ø	c1	f1	J	
Model	keway 2																							
												80-90	100	112	132	160-180								
KL2TR	mm	50	100	14x9	M16	180	150	165	200	25	18	278	174	181	----	----	----	230	265	14	300	16	5	4
KL3TR	mm	60	120	18x11	M20	212	180	180	233	32	22	300	174	181	181	----	----	250	300	18	350	18	5	4
KL4TR	mm	70	140	20x12	M20	265	240	240	295	36	26	340	174	181	181	----	----	350	400	18	450	18	5	8
KL4HR	mm	70	140	20x12	M20	265	240	240	295	36	26	340	----	204	204	224	----	350	400	18	450	18	5	8
KL45HR	mm	90	170	25x14	M24	315	270	270	360	40	33	378	217	217	217	237	267	350	400	18	450	18	5	8
KL5HR	mm	100	190	28x16	M24	375	350	330	420	50	39	450	217	217	217	237	267	450	500	18	550	28	5	8

Modelo	N	No	Vo	V2	W1	W2	Y	e	e1	e2	f	g	h	h1	ht	ht1	n1	n2	n3	n4	Peso kg Weight	aceite lbs oil	
Model																							
KL2TR	mm	55	112	75	40	130	108	25	218	25	263	200	112	288	225.5	310	330	68	60	65	150	103	3,8
KL3TR	mm	70	132	91	55	150	125	30	265	30	310	230	127	340	248	365	387	85	75	70	175	168	5,8
KL4TR	mm	75	160	105	75	192	155	42	330	36	381	290	160	417	285	440	490	95	86	95	225	245	9,3
KL4HR	mm	75	160	105	75	192	155	42	330	36	381	290	160	417	304	440	490	95	86	95	225	250	10,0
KL45HR	mm	95	200	140	95	216	182	41	380	45	465	380	185	503	350	525	524	115	100	115	225	379	16,5
KL5HR	mm	110	225	155	115	256	212	44	465	50	542	400	220	592	404	600	650	130	120	122	275	617	26,5

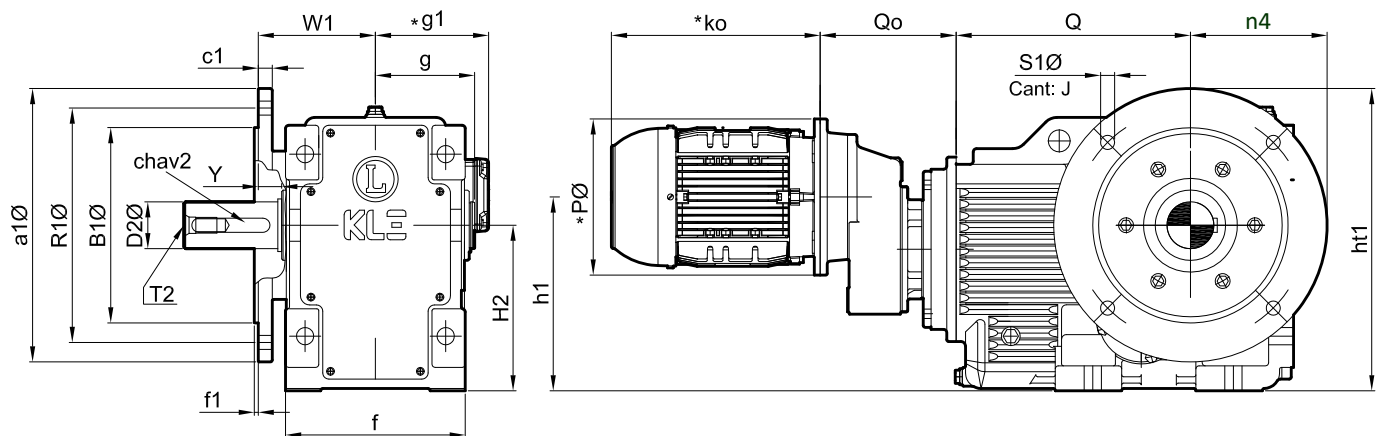

NOTA 1 : Las dimensiones son aproximadas pudiendo modificarse sin aviso previo.

NOTE 1 : Dimensions are for reference only , unless certified.

NOTA 2 : Las capacidades de lubricante son para posición 1A.

NOTE 2 : Oil capacity valid only for mounting position 1A.

NOTA 3 : Para dimensiones ko, P y g1 ver pag. 41 ó catálogo de motores (I.E.C.).

NOTE 3 : To determinate ko, P and g1 see page 41, or electrical motors catalogue (I.E.C.).

NOTA 4 : Los pesos no incluyen peso del motor.

NOTE 4 : Motor weight is not included.

TABLA DE MEDIDAS DE MOTORES ELÉCTRICOS
OVERALL DIMENSIONS - IEC MOTORS

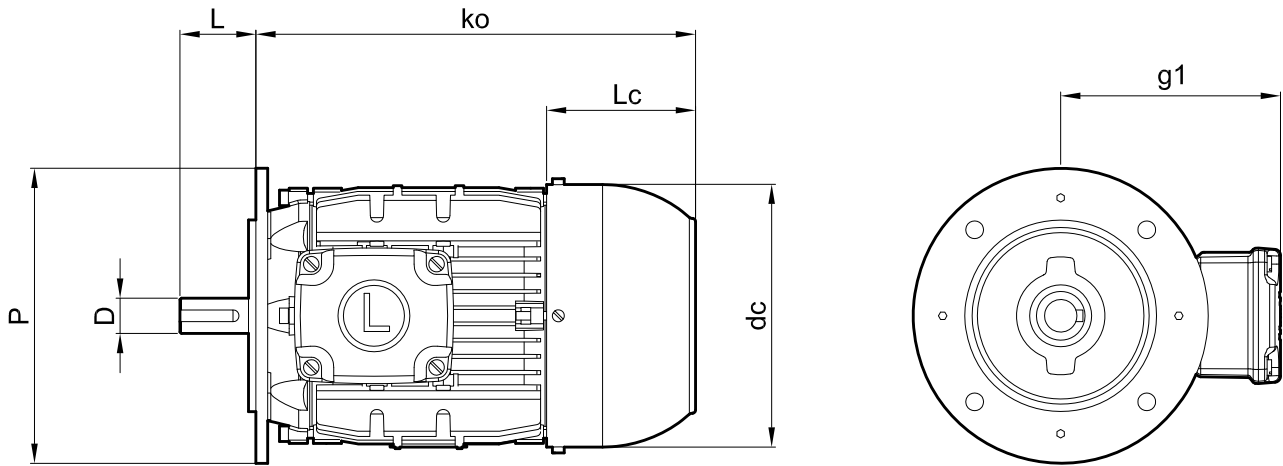

Tamaño Motor IEC. <i>IEC Motor Size</i>							Motor Standard <i>Standard Motor</i>			Motor con Freno <i>Brake Motor</i>			Motor con Antigiro <i>Motor with Backstop</i>		
		Dø	L	Pø	g1	dcø	ko	Lc	Peso kg <i>Weight</i>	ko	Lc	Peso kg <i>Weight</i>	ko	Lc	Peso kg <i>Weight</i>
71	mm	14	30	160	136	138	218	70	10	275	125	12	218	70	10
80	mm	19	40	200	145	158	236	75	14	288	125	16	236	75	14
90 S	mm	24	50	200	155	178	254	80	17,5	314	140	20,5	254	80	17,5
90 L	mm	24	50	200	155	178	279	80	20,5	339	140	23,5	279	80	20,5
100 L	mm	28	60	250	165	198	316	90	30	390	165	35	316	90	30
112 M	mm	28	60	250	190	223	333	100	44,5	413	180	53,5	333	100	44,5
132 S	mm	38	80	300	218	262	372	116	63	487	216	79	432	175	65
132 M	mm	38	80	300	218	262	410	116	73	525	216	89	470	175	75
160 M	mm	42	110	350	256	314	488	140	110	603	240	143	548	200	113
160 L	mm	42	110	350	256	314	532	140	121	647	240	154	592	200	124
180 M	mm	48	110	350	276	358	554	160	165	689	260	198	624	230	168
180 L	mm	48	110	350	276	358	592	160	185	727	260	218	662	230	188
200 M	mm	55	110	400	292	398	619	180	225	-----	-----	-----	689	250	230
200 L	mm	55	110	400	292	398	657	180	240	-----	-----	-----	727	250	245
225 S/M	mm	60	140	450	366	445	707	200	360	-----	-----	-----	-----	-----	-----
250 S/M	mm	65	140	550	366	490	783	225	460	-----	-----	-----	-----	-----	-----
280 S/M	mm	75	140	550	488	555	896	250	650	-----	-----	-----	-----	-----	-----

NOTA: Las medidas son orientativas dependiendo de la marca del motor y están sujetas a futuros cambios en el diseño.
 NOTE: Dimensions are for reference only, unless certified.

CUADRO DE COMPATIBILIDAD GEOMÉTRICA CON MOTORES IEC

PERMISSIBLE IEC FRAME MOTOR SIZES

TAMAÑO DE MOTOR IEC / IEC MOTOR SIZE											
MODELO <i>MODEL</i>	80	90	100	112	132	160	180	200	225	250	280
KL2TR	✓	✓	✓								
KL3TR	✓	✓	✓	✓							
KL4TR	✓	✓	✓	✓							
KL4HR	✓	✓	✓	✓	✓						
KL45HR	✓	✓	✓	✓	✓	✓					
KL5HR	✓	✓	✓	✓	✓	✓	✓				
KL2	✓	✓	✓	✓	✓	✓					
KL3		✓	✓	✓	✓	✓	✓				
KL4			✓	✓	✓	✓	✓				
KL45			✓	✓	✓	✓	✓	✓	✓		
KL5			✓	✓	✓	✓	✓	✓	✓	✓	✓

NOTA 1 : Para más detalles ver catalogo de motores (I.E.C.) y Tabla de Potencias.

NOTE 1 : For more details see electrical motors catalogue (I.E.C.) and Power Rating Table.

NOTA 2 : Para cada tamaño de motor no todas las relaciones son posibles ver tabla de potencias.

NOTE 2 : For every motor size see Power Rating Table for permissible ratios.

DIAGRAMA DE SELECCIÓN RÁPIDA

QUICK SELECTION DIAGRAM



TABLA DE SELECCIÓN PARA RELACIONES NOMINALES ENTRE 7/1 y 28/1
SELECTION TABLE FOR NOMINAL RATIO BETWEEN 7 / 1 and 28 / 1

Relación Nominal <i>Nominal Ratio</i>	Velocidad de entrada <i>Input R.P.M.</i>	KL2		KL3		KL4		KL45		KL5	
		i	Ne (Kw)	i	Ne (Kw)	i	Ne (Kw)	i	Ne (Kw)	i	Ne (Kw)
7	1500		---		49,70		---		134,26		---
	1000		---		33,13		---		89,51		---
	750	---	---	6,96	24,85	---	---	7,18	67,13	---	---
	500		---		16,57		---		44,75		---
	300		---		9,94		---		26,85		---
8	1500		---		43,67		85,15		116,76		170,00
	1000		---		29,11		56,76		77,84		113,33
	750	---	---	7,93	21,83	8,29	42,57	8,27	58,38	8,73	85,00
	500		---		14,56		28,38		38,92		56,67
	300		---		8,73		17,03		23,35		34,00
9	1500		22,50		38,22		75,51		101,18		150,00
	1000		15,00		25,48		50,34		67,45		100,00
	750	9,43	11,25	9,08	19,11	9,35	37,76	9,57	50,59	9,91	75,00
	500		7,50		12,74		25,17		33,73		50,00
	300		4,50		7,64		15,10		20,24		30,00
10	1500		20,07		41,68		66,68		88,97		131,62
	1000		13,38		27,78		44,45		59,31		87,75
	750	11,04	10,04	10,19	20,84	10,59	33,34	11,16	44,49	11,32	65,81
	500		6,69		13,89		22,23		29,66		43,87
	300		4,01		8,34		13,34		17,79		26,32
13	1500		17,65		37,65		57,85		86,99		114,41
	1000		11,76		25,10		38,57		57,99		76,27
	750	13,04	8,82	11,62	18,82	12,21	28,93	12,14	43,49	13,04	57,21
	500		5,88		12,55		19,28		29,00		38,14
	300		3,53		7,53		11,57		17,40		22,88
14	1500		15,28		33,90		51,32		79,63		109,00
	1000		10,19		22,60		34,21		53,09		72,67
	750	15,02	7,64	13,30	16,95	13,77	25,66	13,99	39,82	15,05	54,50
	500		5,09		11,30		17,11		26,54		36,33
	300		3,06		6,78		10,26		15,93		21,80
16	1500		15,12		30,37		45,29		70,96		---
	1000		10,08		20,25		30,20		47,31		---
	750	15,58	7,56	15,31	15,18	15,60	22,65	16,19	35,48	---	---
	500		5,04		10,12		15,10		23,65		---
	300		3,02		6,07		9,06		14,19		---
18	1500		13,51		27,09		39,73		63,24		103,00
	1000		9,00		18,06		26,49		42,16		68,67
	750	17,59	6,75	17,74	13,54	17,78	19,86	18,87	31,62	17,08	51,50
	500		4,50		9,03		13,24		21,08		34,33
	300		2,70		5,42		7,95		12,65		20,60
20	1500		12,45		23,77		34,57		---		98,00
	1000		8,30		15,85		23,05		---		65,33
	750	18,93	6,22	20,76	11,89	20,43	17,29	---	---	19,52	49,00
	500	(*)	4,15		7,92		11,52		---		32,67
	300		2,49		4,75		6,91		---		19,60
22,5	1500		11,84		21,45		29,78		55,18		92,00
	1000		7,89		14,30		19,85		36,78		61,33
	750	20,77	5,92	23,00	10,72	23,72	14,89	22,19	27,59	22,47	46,00
	500		3,95		7,15		9,93		18,39		30,67
	300		2,37		4,29		5,96		11,04		18,40
25	1500		10,12		20,06		---		46,35		86,69
	1000		6,75		13,37		---		30,90		57,79
	750	24,83	5,06	24,60	10,03	---	---	26,42	23,18	26,14	43,35
	500		3,37		6,69		---		15,45		28,90
	300		2,02		4,01		---		9,27		17,34
28	1500		8,33		18,82		25,64		44,71		---
	1000		5,55		12,55		17,09		29,80		---
	750	30,16	4,17	26,20	9,41	27,60	12,82	27,39	22,35	---	---
	500		2,78		6,27		8,55		14,90		---
	300		1,67		3,76		5,13		8,94		---

(*) En ejecución "R" consultar disponibilidad . Las características y dimensiones pueden variar o ser diferentes a las publicadas.

(*) For gearboxes with input shaft ask Lentax about availability. Features and dimensions may vary.

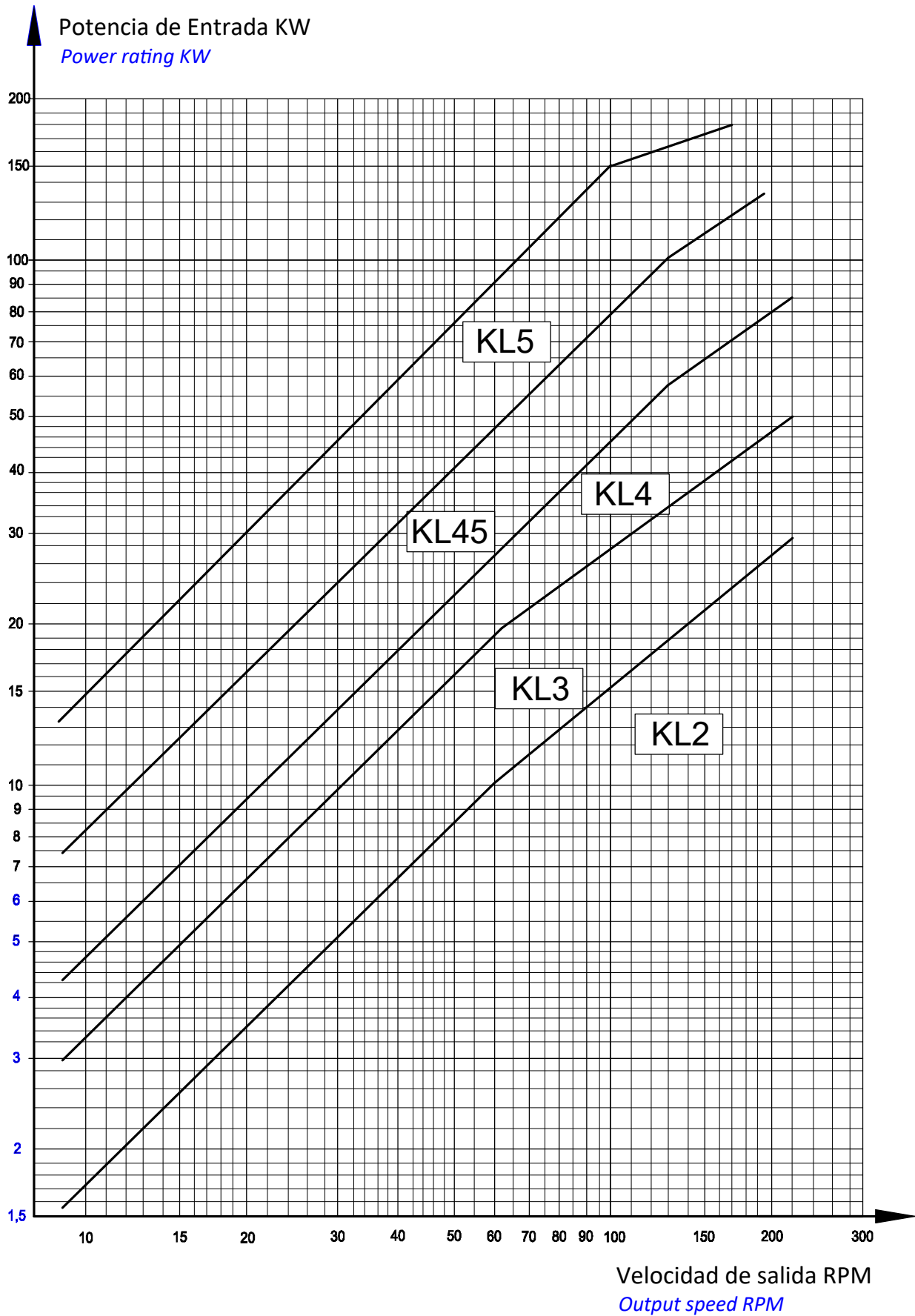
TABLA DE SELECCIÓN PARA RELACIONES NOMINALES ENTRE 30/1 y 112/1

SELECTION TABLE FOR NOMINAL RATIO BETWEEN 30/1 and 112/1

Relación Nominal <i>Nominal Ratio</i>	Velocidad de entrada <i>Input R.P.M.</i>	KL2		KL3		KL4		KL45		KL5	
		i	Ne (Kw)	i	Ne (Kw)	i	Ne (Kw)	i	Ne (Kw)	i	Ne (Kw)
30	1500		7,41		16,44		22,74		---		73,26
	1000		4,94		10,96		15,16		---		48,84
	750	33,90	3,71	30,00	8,22	31,10	11,37	---	---	30,80	36,63
	500		2,47		5,48		7,58		---		24,42
	300		1,48		3,29		4,55		---		14,65
31,5	1500		7,14		14,29		21,14		38,79		66,57
	1000		4,76		9,52		14,09		25,86		44,38
	750	35,16	3,57	34,50	7,14	33,42	10,57	31,60	19,40	33,95	33,29
	500		2,38		4,76	(*)	7,05		12,93		22,19
	300		1,43		2,86		4,23		7,76		13,31
35,5	1500		6,70		13,48		20,07		33,51		61,06
	1000		4,47		8,99		13,38		22,34		40,71
	750	37,50	3,35	36,60	6,74	35,20	10,04	36,50	16,76	36,94	30,53
	500	(*)	2,23	(*)	4,49		6,69		11,17	(*)	20,35
	300		1,34		2,70		4,01		6,70		12,21
40	1500		6,33		12,33		17,60		30,90		58,45
	1000		4,22		10,20		11,74		20,60		38,97
	750	39,70	3,17	40,00	7,65	40,10	8,80	39,63	15,45	38,60	29,22
	500		2,11		5,10		5,87		10,30		19,48
	300		1,27		3,06		3,52		6,18		11,69
45	1500		5,36		10,53		16,51		28,76		50,94
	1000		3,57		9,12		11,01		19,17		33,96
	750	46,90	2,68	46,80	6,84	42,78	8,26	42,60	14,38	44,00	25,47
	500		1,79		4,56		5,50		9,59		16,98
	300		1,07		2,74		3,30		5,75		10,19
50	1500		5,21		---		15,32		24,45		44,03
	1000		3,47		---		10,21		16,30		29,35
	750	48,20	2,60	---	---	46,10	7,66	50,10	12,22	50,70	22,01
	500	(*)	1,74		---		5,11		8,15		14,68
	300		1,04		---		3,06		4,89		8,81
56	1500		4,73		8,89		13,20		20,54		37,73
	1000		3,15		8,14		8,80		13,69		25,15
	750	53,11	2,36	55,50	6,10	53,50	6,60	59,60	10,27	59,00	18,86
	500	(*)	1,58		4,07		4,40		6,85		12,58
	300		0,95		2,44		2,64		4,11		7,55
63	1500		4,48		7,37		11,21		18,06		---
	1000		2,99		6,13		7,48		12,04		---
	750	56,00	2,24	66,90	4,60	63,00	5,61	67,80	9,03	---	---
	500		1,49	(*)	3,06		3,74	(*)	6,02		---
	300		0,90		1,84		2,24		3,61		---
71	1500		3,69		5,97		9,37		16,97		32,01
	1000		2,46		5,74		6,25		11,31		21,34
	750	68,10	1,85	82,60	4,30	75,40	4,68	72,20	8,49	69,50	16,00
	500	(*)	1,23	(*)	2,87	(*)	3,12	(*)	5,66		10,67
	300		0,74		1,72		1,87		3,39		6,40
90	1500		2,97		---		7,64		13,69		26,96
	1000		1,98		---		5,09		9,13		17,98
	750	84,60	1,49	---	---	92,50	3,82	89,40	6,85	83,40	13,48
	500	(*)	0,99		---	(*)	2,55	(*)	4,56	(*)	8,99
	300		0,59		---		1,53		2,74		5,39
100	1500		---		4,68		---		---		22,36
	1000		---		4,80		---		---		14,91
	750	---	---	105,5	3,60	---	---	---	---	102,4	11,18
	500		---	(*)	2,40		---		---	(*)	7,45
	300		---		1,44		---		---		4,47
112	1500		2,31		---		6,01		10,68		---
	1000		1,54		---		4,01		7,12		---
	750	108,8	1,15	---	---	117,5	3,01	114,6	5,34	---	---
	500	(*)	0,77		---	(*)	2,00	(*)	3,56		---
	300		0,46		---		1,20		2,14		---

(*) En ejecución "R" consultar disponibilidad . Las características y dimensiones pueden variar o ser diferentes a las publicadas.

(*) For gearboxes with input shaft ask Lentax about availability. Features and dimensions may vary.

TABLA DE MEDIDAS - SERIE " RKL " (CON EJE DE SALIDA HUECO)
OVERALL DIMENSIONS - TYPE " RKL " (WITH OUTPUT HOLLOW SHAFT)

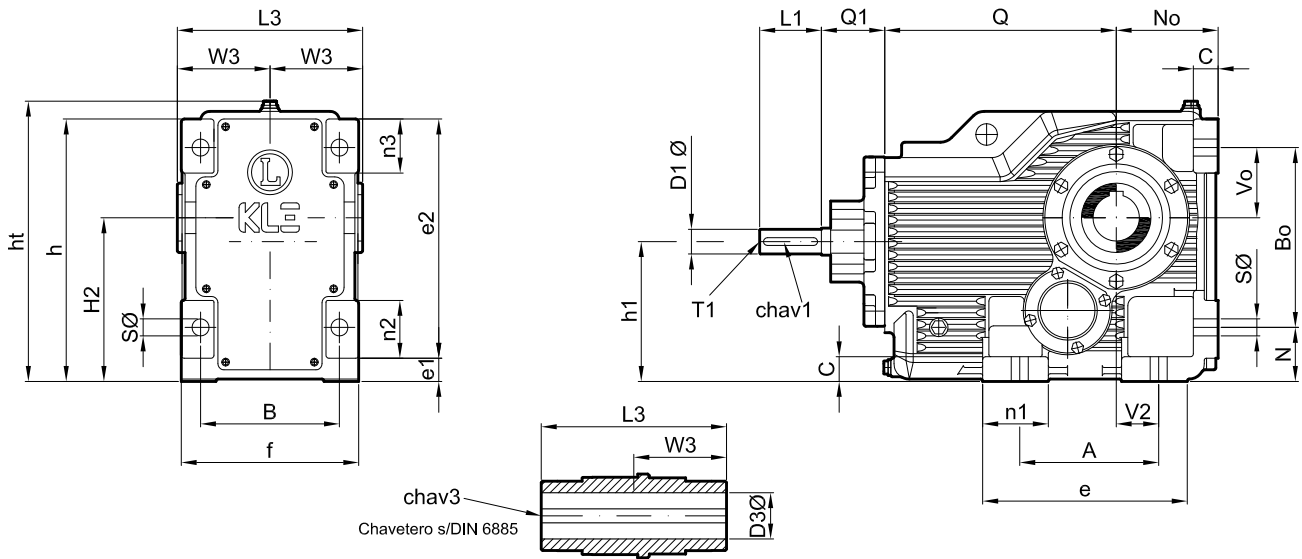

Modelo	D1 \emptyset	L1	chav 1	T1	D3 \emptyset	L3	chav 3	W3	H2	A	B	Bo	C	S \emptyset	Q	Q1	B1 \emptyset	R1 \emptyset	S1 \emptyset	a1 \emptyset	c1	f1	J	
<i>Model</i>	<i>keyway 1</i>			<i>keyway 3</i>																				
RKL2	mm	32	80	10 x 8	M12	50	210	14x9	105	180	150	165	200	25	18	278	82	230	265	14	300	16	5	4
RKL3	mm	32	80	10 x 8	M12	60	240	18x11	120	212	180	180	233	32	22	300	82	250	300	18	350	18	5	4
RKL4	mm	32	80	10 x 8	M12	70	300	20x12	150	265	240	240	295	36	26	340	82	350	400	18	450	18	5	8
RKL45	mm	42	110	12 x 8	M16	90	350	25x14	175	315	270	270	360	40	33	378	113	350	400	18	450	18	5	8
RKL5	mm	48	110	14 x 9	M16	100	412	28x16	206	375	350	330	420	50	39	450	113	450	500	18	550	28	5	8

Modelo	N	No	Vo	V2	W1	Y	e	e1	e2	f	h	h1	ht	ht1	n1	n2	n3	n4	Peso kg Weight	aceite lts oil	
<i>Model</i>																					
RKL2	mm	55	112	75	40	130	25	218	25	263	200	288	158,5	310	330	68	60	65	150	89	3,0
RKL3	mm	70	132	91	55	150	30	265	30	310	230	340	181	365	387	85	75	70	175	149	5,0
RKL4	mm	75	160	105	75	192	42	330	36	381	290	417	218	440	490	95	86	95	225	219	8,5
RKL45	mm	95	200	140	95	216	41	380	45	465	340	503	264	525	524	115	100	115	225	345	15
RKL5	mm	110	225	155	115	256	44	465	50	542	400	592	318	600	650	130	120	122	275	565	25

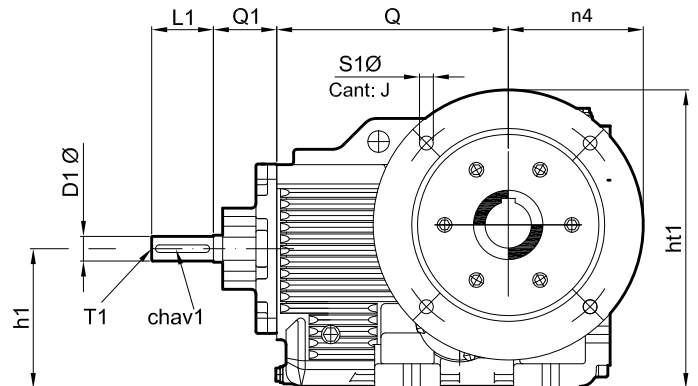
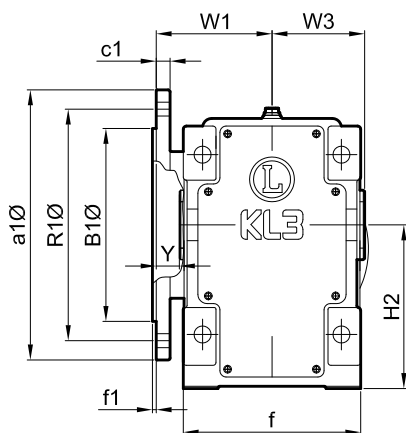

NOTA 1 : Las dimensiones son aproximadas pudiendo modificarse sin aviso previo.

NOTE 1 : Dimensions are for reference only , unless certified.

NOTA 2 : Las capacidades de lubricante son para posición 1A

NOTE 2 : Oil capacity valid only for mounting position 1A.

TABLA DE MEDIDAS - SERIE " RKL " (CON EJE DE SALIDA MACIZO)
OVERALL DIMENSIONS - TYPE " RKL " (WITH OUTPUT SOLID SHAFT)

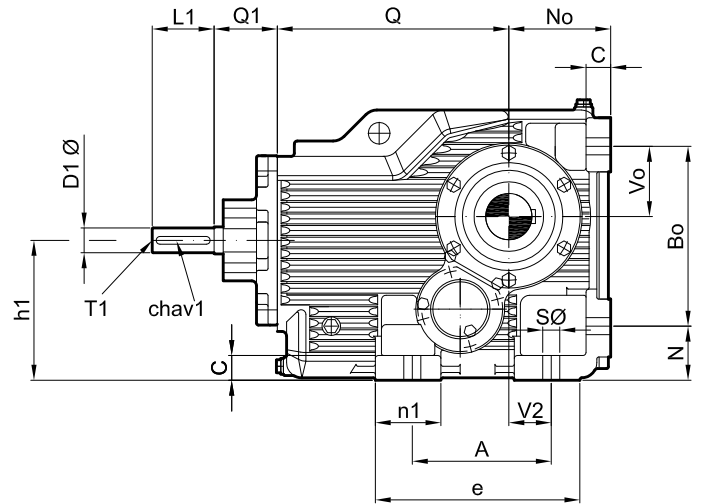
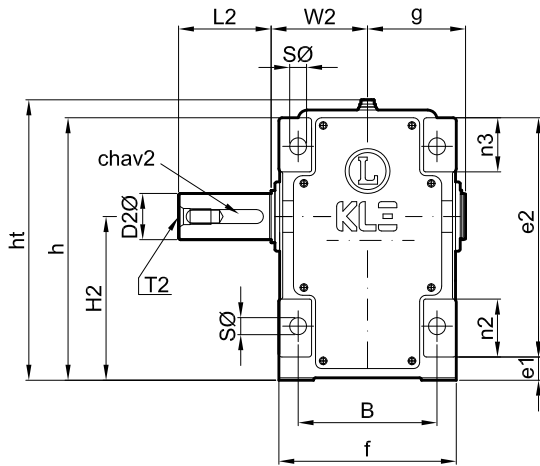

Modelo	D1Ø	L1	chav 1	T1	D2Ø	L2	chav 2	T2	H2	A	B	Bo	C	SØ	Q	Q1	B1Ø	R1Ø	S1Ø	a1Ø	c1	f1	J	
<i>Model</i>			<i>keyway 1</i>				<i>keyway 2</i>																	
RKL2	mm	32	80	10 x 8	M12	50	100	14x9	M16	180	150	165	200	25	18	278	82	230	265	14	300	16	5	4
RKL3	mm	32	80	10 x 8	M12	60	120	18x11	M20	212	180	180	233	32	22	300	82	250	300	18	350	18	5	4
RKL4	mm	32	80	10 x 8	M12	70	140	20x12	M20	265	240	240	295	36	26	340	113	350	400	18	450	18	5	8
RKL45	mm	42	110	12 x 8	M16	90	170	25x14	M24	315	270	270	360	40	33	378	113	350	400	18	450	18	5	8
RKL5	mm	48	110	14 x 9	M16	100	412	28x16	M24	375	350	330	420	50	39	450	113	450	500	18	550	28	5	8

Modelo	N	No	Vo	V2	W1	W2	Y	e	e1	e2	f	g	h	h1	ht	ht1	n1	n2	n3	n4	Peso kg <i>Weight</i>	aceite lts <i>oil</i>	
<i>Model</i>																							
RKL2	mm	55	112	75	40	130	108	25	218	25	263	200	112	288	158,5	310	330	68	60	65	150	94	3,0
RKL3	mm	70	132	91	55	150	125	30	265	30	310	230	127	340	181	365	387	85	75	70	175	157	5,0
RKL4	mm	75	160	105	75	192	155	42	330	36	381	290	160	417	218	440	490	95	86	95	225	232	8,5
RKL45	mm	95	200	140	95	216	182	41	380	45	465	340	185	503	264	525	524	115	100	115	225	374	15
RKL5	mm	110	225	155	115	256	212	44	465	50	542	400	220	592	318	600	650	130	120	122	275	612	25

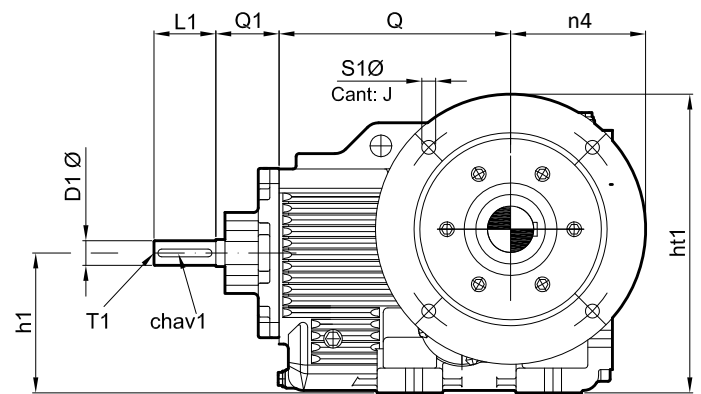
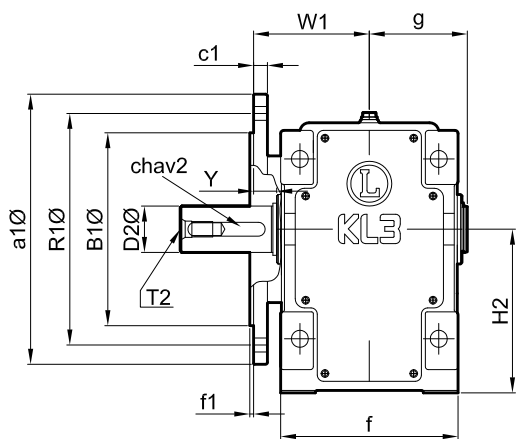

NOTA 1 : Las dimensiones son aproximadas pudiendo modificarse sin aviso previo.
 NOTE 1 : Dimensions are for reference only , unless certified.
 NOTA 2 : Las capacidades de lubricante son para posición 1A.
 NOTE 2 : Oil capacity valid only for mounting position 1A.

TABLA DE MEDIDAS - SERIE " RKL " (CON EJE DE SALIDA HUECO Y ANTECAJA DE SIMPLE REDUCCI3N)
OVERALL DIMENSIONS - TYPE " RKL " (WITH OUTPUT HOLLOW SHAFT AND PRIMARY ONE-STEP GEARBOX)

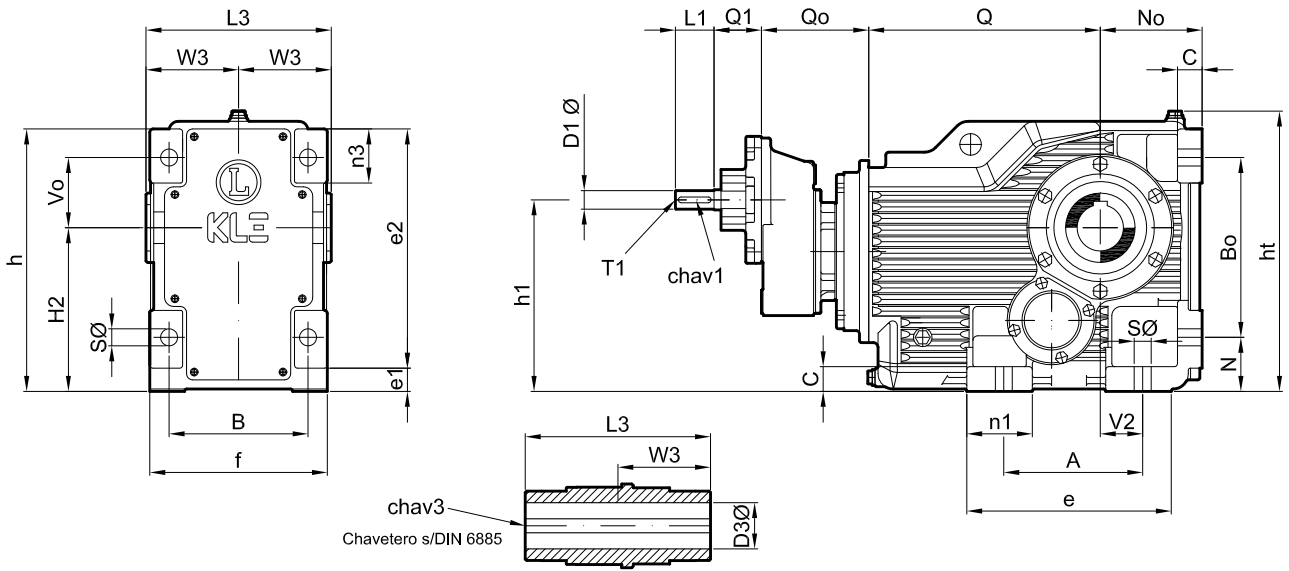

Modelo	D1Ø	L1	chav 1	T1	D3Ø	L3	chav 3	W3	H2	A	B	Bo	C	SØ	Q	Qo	Q1	B1Ø	R1Ø	S1Ø	a1Ø	c1	f1	J		
Model	keyway 1			keyway 3																						
RKL2TR	mm	24	50	8 x 7	M8	50	210	14x9	105	180	150	165	200	25	18	278	139	61	230	265	14	300	16	5	4	
RKL3TR	mm	24	50	8 x 7	M8	60	240	18x11	120	212	180	180	233	32	22	300	139	61	250	300	18	350	18	5	4	
RKL4TR	mm	24	50	8 x 7	M8	70	300	20x12	150	265	240	240	295	36	26	340	139	61	350	400	18	450	18	5	8	
RKL4HR	mm	32	80	10 x 8	M12	70	300	20x12	150	265	240	240	295	36	26	340	172	82	350	400	18	450	18	5	8	
RKL45HR	mm	32	80	10 x 8	M12	90	350	25x14	175	315	270	270	360	40	33	378	172	82	350	400	18	450	18	5	8	
RKL5HR	mm	48	110	14 x 9	M16	100	412	28x16	206	375	350	330	420	50	39	450	185	145	450	500	18	550	28	5	8	

Modelo	N	No	Vo	V2	W1	Y	e	e1	e2	f	h	h1	ht	ht1	n1	n2	n3	n4	Peso	aceite	
Model																			kg	lbs	oil
RKL2TR	mm	55	112	75	40	130	25	218	25	263	200	288	225,5	310	330	68	60	65	150	101	3,8
RKL3TR	mm	70	132	91	55	150	30	265	30	310	230	340	248	365	387	85	75	70	175	161	5,8
RKL4TR	mm	75	160	105	75	192	42	330	36	381	290	417	285	440	490	95	86	95	225	232	9,3
RKL4HR	mm	75	160	105	75	192	42	330	36	381	290	417	304	440	490	95	86	95	225	240	10,0
RKL45HR	mm	95	200	140	95	216	41	380	45	465	340	503	350	525	524	115	100	115	225	354	16,5
RKL5HR	mm	110	225	155	115	256	44	465	50	542	400	592	318	600	650	130	120	122	275	573	26,5

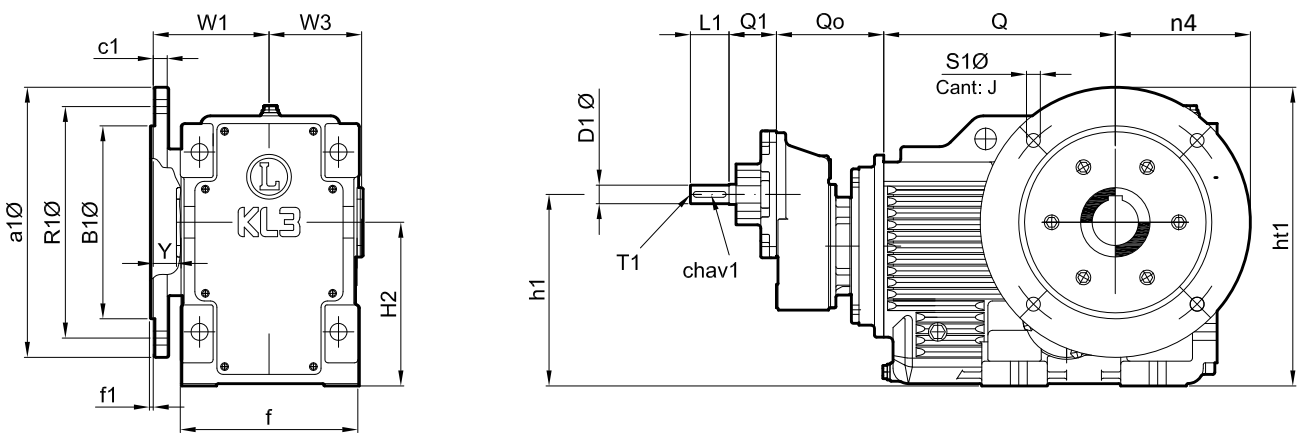

NOTA 1 : Las dimensiones son aproximadas pudiendo modificarse sin aviso previo.
 NOTE 1 : Dimensions are for reference only , unless certified.
 NOTA 2 : Las capacidades de lubricante son para posición 1A.
 NOTE 2 : Oil capacity valid only for mounting position 1A.

TABLA DE MEDIDAS - SERIE " RKL " (CON EJE DE SALIDA MACIZO Y ANTECAJA DE SIMPLE REDUCCIÓN)
OVERALL DIMENSIONS - TYPE " RKL " (WITH OUTPUT SOLID SHAFT AND PRIMARY ONE-STEP GEARBOX)

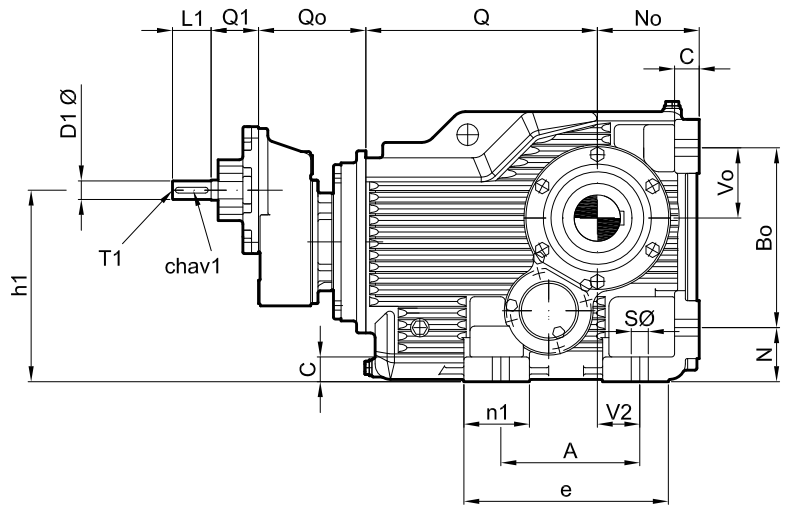
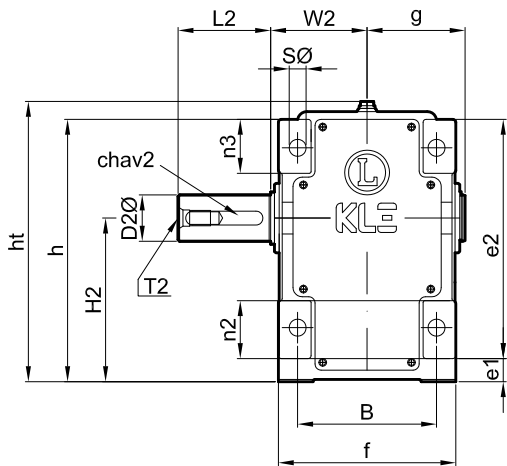

Modelo	D1Ø	L1	chav 1	T1	D2Ø	L2	chav 2	T2	H2	A	B	Bo	C	SØ	Q	Qo	Q1	B1Ø	R1Ø	S1Ø	a1Ø	c1	f1	J		
Model	keyway 1			keyway 2																						
RKL2TR	mm	24	50	8 x 7	M8	50	100	14x9	M16	180	150	165	200	25	18	278	139	61	230	265	14	300	16	5	4	
RKL3TR	mm	24	50	8 x 7	M8	60	120	18x11	M20	212	180	180	233	32	22	300	139	61	250	300	18	350	18	5	4	
RKL4TR	mm	24	50	8 x 7	M8	70	140	20x12	M20	265	240	240	295	36	26	340	139	61	350	400	18	450	18	5	8	
RKL4HR	mm	32	80	10 x 8	M12	70	140	20x12	M20	265	240	240	295	36	26	340	172	82	350	400	18	450	18	5	8	
RKL45HR	mm	32	80	10 x 8	M12	90	170	25x14	M24	315	270	270	360	40	33	378	172	82	350	400	18	450	18	5	8	
RKL5HR	mm	48	110	14 x 9	M16	100	412	28x16	M24	375	350	330	420	50	39	450	185	145	450	500	18	550	28	5	8	

Modelo	N	No	Vo	V2	W1	W2	Y	e	e1	e2	f	g	h	h1	ht	ht1	n1	n2	n3	n4	Peso	aceite	
Model																					kg	lbs	
																						Weight	oil
RKL2TR	mm	55	112	75	40	130	108	25	218	25	263	200	112	288	225,5	310	330	68	60	65	150	106	3,8
RKL3TR	mm	70	132	91	55	150	125	30	265	30	310	230	127	340	248	365	387	85	75	70	175	169	5,8
RKL4TR	mm	75	160	105	75	192	155	42	330	36	381	290	160	417	285	440	490	95	86	95	225	245	9,3
RKL4HR	mm	75	160	105	75	192	155	42	330	36	381	290	160	417	304	440	490	95	86	95	225	253	10,0
RKL45HR	mm	95	200	140	95	216	182	41	380	45	465	340	185	503	350	525	524	115	100	115	225	383	16,5
RKL5HR	mm	110	225	155	115	256	212	44	465	50	542	400	220	592	318	600	650	130	120	122	275	573	26,5

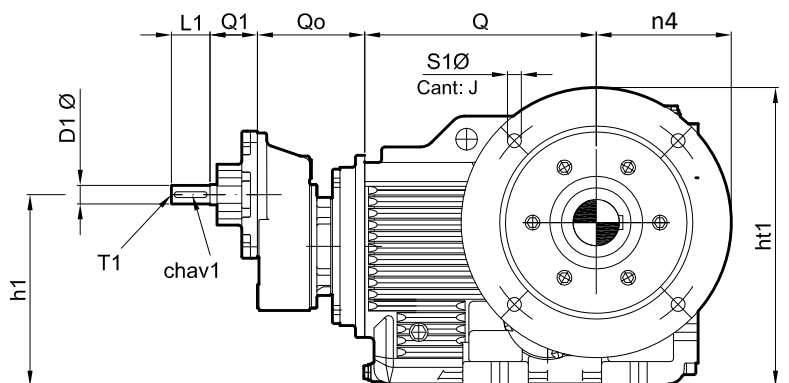
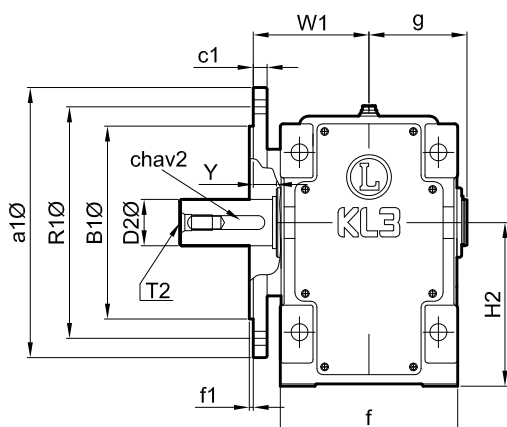

NOTA 1 : Las dimensiones son aproximadas pudiendo modificarse sin aviso previo.

NOTE 1 : Dimensions are for reference only , unless certified.

NOTA 2 : Las capacidades de lubricante son para posición 1A.

NOTE 2 : Oil capacity valid only for mounting position 1A.

POSICIONES DE MONTAJE

MOUNTING POSITIONS

Montaje con Eje Sólido

With solid shaft

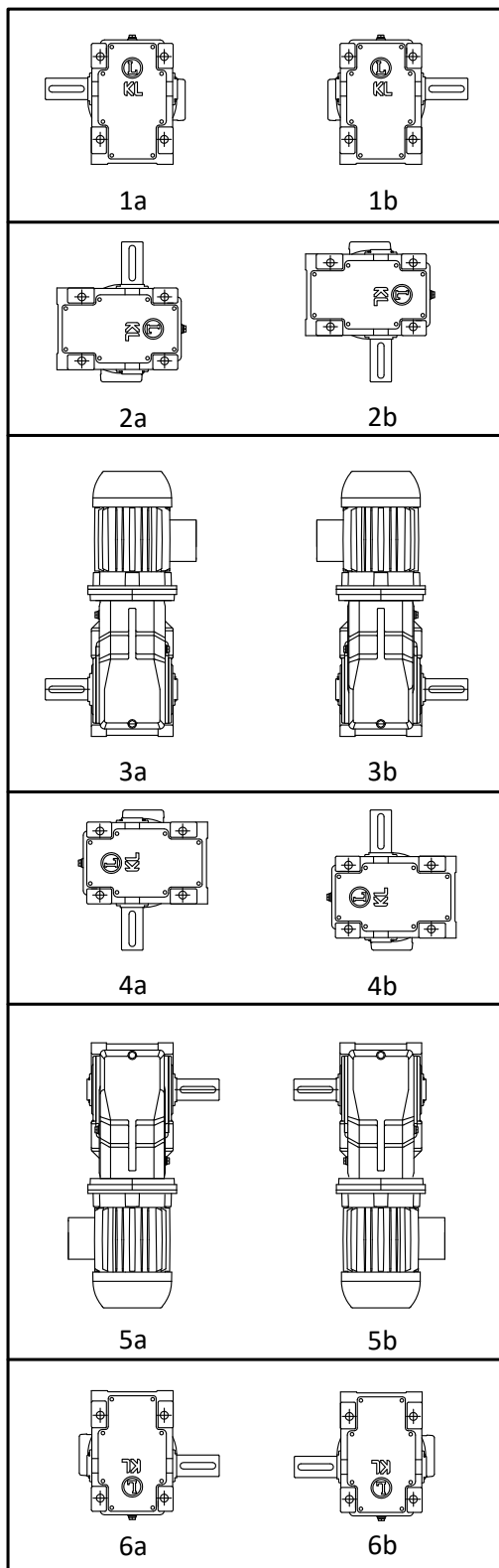

Montaje con Eje Hueco

With hollow shaft

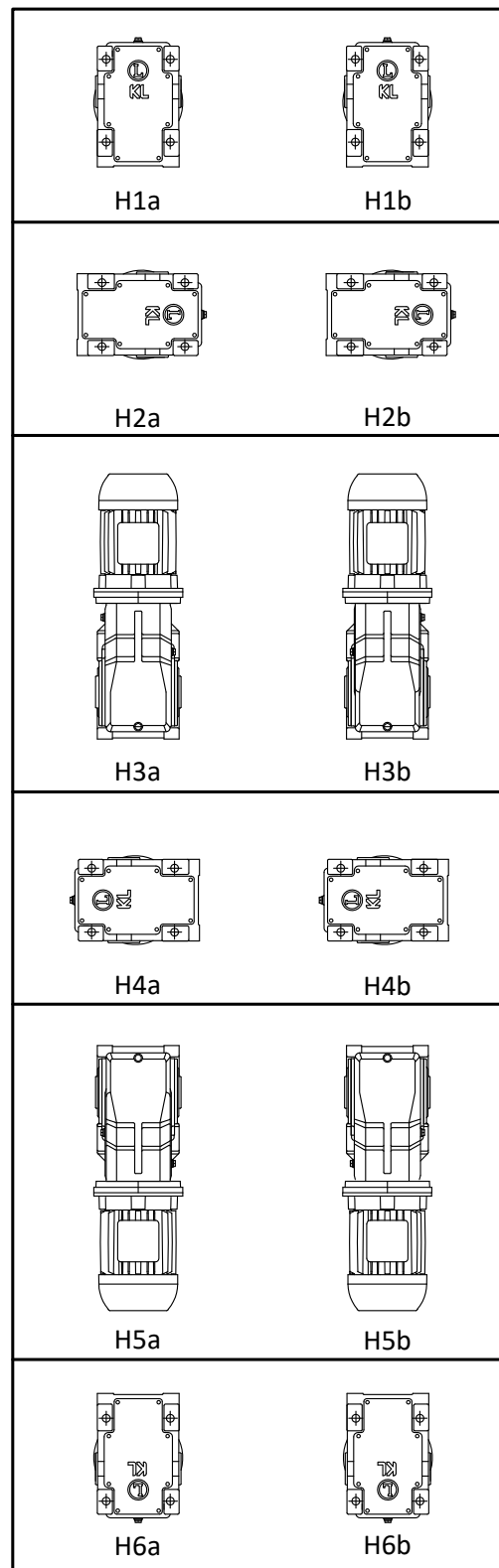

NOTA 1 : Para montaje con brida de salida anteponer la letra "B" por ejemplo B1a , BH1a.

NOTA 1 : Para montaje con brida de salida anteponer la letra "B" por ejemplo B1a , BH1a.

NOTA 2 : Para montaje con eje de salida doble utilizar las letras "ab" por ejemplo 1ab.

NOTA 2 : Para montaje con eje de salida doble utilizar las letras "ab" por ejemplo 1ab.

GUIA PARA SOLICITUD DE PARTES

PART LIST GUIDE

LINEA "KL"

TYPE "KL"

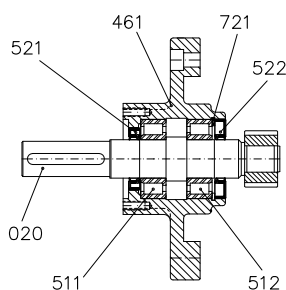

TROMPA DE ENTRADA
INPUT TURRET

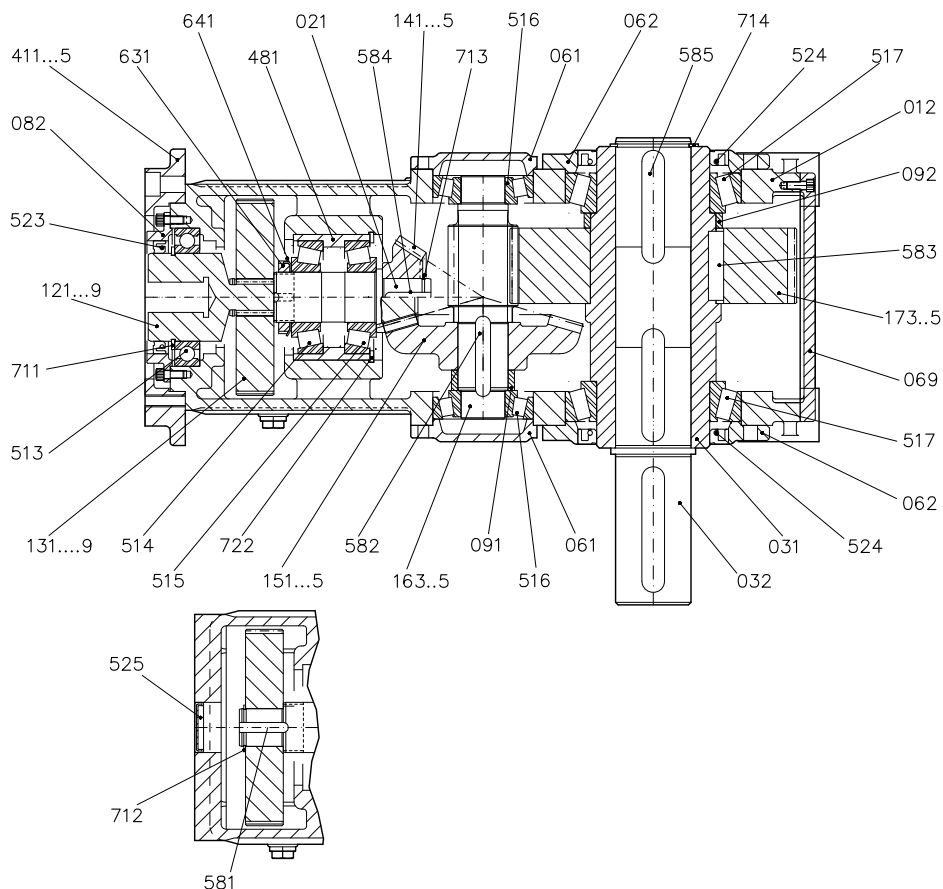

LISTA DE PARTES

PART LIST

012	Cuerpo	012	<i>Gearbox case</i>	514	Rodamiento piñón cónico	514	<i>Roller bearing</i>
020	Eje de entrada reductor	020	<i>Input shaft</i>	515	Rodamiento piñón cónico	515	<i>Roller bearing</i>
021	Eje intermedio piñón buje	021		516	Rodamiento piñón de salida	516	<i>Roller bearing</i>
031	Eje de salida hueco	031	<i>Hollow output shaft</i>	517	Rodamiento engranaje de salida	517	<i>Roller bearing</i>
032	Eje de salida	032	<i>Output shaft</i>	521	Reten en trompa entrada	521	<i>Input oil seal</i>
061	Tapa de etapa intermedia	061	<i>Lateral cover</i>	522	Reten en trompa lado reductor	522	<i>Input oil seal</i>
062	Tapa de salida	062	<i>Output cover</i>	523	Reten piñón de entrada	523	<i>Input oil seal</i>
069	Tapa de inspección	069	<i>Inspection cover</i>	524	Retén de Salida	524	<i>Input oil seal</i>
082	Contratapa retén de entrada	082	<i>Oil seal input cover</i>	525	Tapón de cierre	525	<i>End cover</i>
091	Distanciador engranaje cónico	091	<i>Spacer</i>	581	Chaveta engranaje de entrada	581	<i>Key</i>
092	Distanciador engranaje salida	092	<i>Spacer</i>	582	Chaveta engranaje de intermedia	582	<i>Key</i>
112...9	Piñón de entrada	112...9	<i>Input pinion</i>	583	Chaveta engranaje de salida	583	<i>Key</i>
113...9	Engranaje de entrada	113...9	<i>Input gear</i>	584	Chaveta piñón cónico buje	584	<i>Key</i>
141...5	Piñón cónico	141...5	<i>Bevel pinion</i>	585	Chaveta eje de salida sólido	585	<i>Key</i>
151...5	Engranaje cónico	151...5	<i>Bevel gear</i>	631	Tuerca de fijación KM	631	<i>Locknut</i>
161...5	Piñón de salida	161...5	<i>Output pinion</i>	641	Arandela de obturación MB	641	<i>Lockwasher</i>
171...5	Engranaje de salida	171...5	<i>Output gear</i>	711	Seeger piñón de entrada	711	<i>Snap ring</i>
411...5	Aro IEC	411...5	<i>IEC input flange</i>	712	Seeger engranaje de entrada	712	<i>Snap ring</i>
461	Trompa de entrada	461	<i>Input turret</i>	713	Seeger piñón cónico	713	<i>Snap ring</i>
481	Caja porta-rodamiento	481	<i>Bearing case</i>	714	Seeger eje de salida macizo	714	<i>Snap ring</i>
511	Rodamiento trompa lado entrada	511	<i>Roller bearing</i>	721	Seeger en trompa de entrada	721	<i>Snap ring</i>
512	Rodamiento trompa lado reductor	512	<i>Roller bearing</i>	722	Seeger caja porta-rodamiento	722	<i>Snap ring</i>
513	Rodamiento piñón de entrada	513	<i>Roller bearing</i>				



PRODUCTOS RESPALDADOS POR CINCUENTA AÑOS DE EXPERIENCIA Y EVOLUCIÓN

Austria Norte 1158 Tigre - Buenos Aires - Argentina

- Tel. 054-11-5252-1940 (líneas rotativas)
- E-mail: ventas@lentax.com
- web [HTTP://www.lentax.com](http://www.lentax.com)